

Surname					Other Names				
Centre Number					Candidate Number				
Candidate Signature									

Leave blank
-------------

General Certificate of Secondary Education  
November 2003



**MATHEMATICS (SPECIFICATION A) 3301/2H**  
**Higher Tier**  
**Paper 2 Calculator**

**H**

Friday 14 November 2003 9.00 am to 11.00 am

<p><b>In addition to this paper you will require:</b></p> <ul style="list-style-type: none"> <li>• a calculator</li> <li>• mathematical instruments.</li> </ul>	
-----------------------------------------------------------------------------------------------------------------------------------------------------------------	--

For Examiner's Use	
Pages	Mark
3	
4 – 5	
6 – 7	
8 – 9	
10 – 11	
12 – 13	
14 – 15	
16 – 17	
18 – 19	
20 – 21	
22 – 23	
24	
TOTAL	
Examiner's Initials	

Time allowed: 2 hours

**Instructions**

- Use blue or black ink or ball-point pen. Draw diagrams in pencil.
- Fill in the boxes at the top of this page.
- Answer **all** questions in the spaces provided.
- Do all rough work in this booklet.
- If your calculator does not have a  $\pi$  button, take the value of  $\pi$  to be 3.14 unless otherwise instructed in the question.

**Information**

- The maximum mark for this paper is 100.
- Mark allocations are shown in brackets.
- Additional answer paper, graph paper and tracing paper will be issued on request and must be tagged securely to this answer booklet.
- You are expected to use a calculator where appropriate.

**Advice**

- In all calculations, show clearly how you work out your answer.

### Formulae Sheet: Higher Tier

You may need to use the following formulae:

**Volume of prism** = area of cross-section  $\times$  length

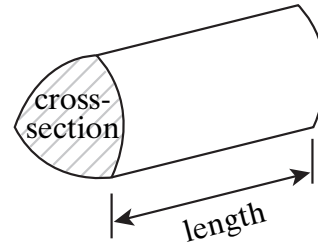

**Volume of sphere** =  $\frac{4}{3} \pi r^3$

**Surface area of sphere** =  $4 \pi r^2$

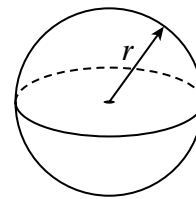

**Volume of cone** =  $\frac{1}{3} \pi r^2 h$

**Curved surface area of cone** =  $\pi r l$

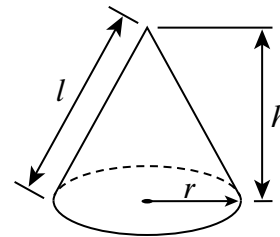

**In any triangle ABC**

**Area of triangle** =  $\frac{1}{2} ab \sin C$

**Sine rule**  $\frac{a}{\sin A} = \frac{b}{\sin B} = \frac{c}{\sin C}$

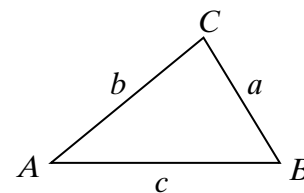

**Cosine rule**  $a^2 = b^2 + c^2 - 2bc \cos A$

**The Quadratic Equation**

The solutions of  $ax^2 + bx + c = 0$ , where  $a \neq 0$ , are given by

$$x = \frac{-b \pm \sqrt{b^2 - 4ac}}{2a}$$

Answer **all** questions in the spaces provided.

1 The sizes of the interior angles of a quadrilateral are in the ratio

$$3 : 4 : 6 : 7$$

Calculate the size of the largest angle.

.....  
.....  
.....  
.....

Answer ..... degrees (3 marks)

2 A semi-circular protractor has a diameter of 9 cm.

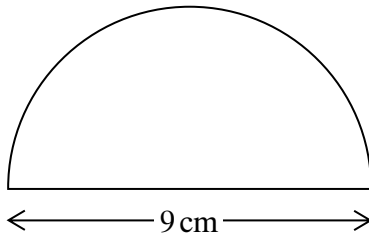

Not drawn accurately

Calculate the perimeter.

.....  
.....  
.....  
.....

Answer ..... cm (3 marks)

- 3 The probabilities of whether a student, picked at random from a school, is vegetarian or not are shown in this table.

	Boys	Girls
Vegetarian	0.08	0.2
Non-vegetarian	0.4	0.32

- (a) What is the probability that a student chosen at random from the school is vegetarian?

.....  
 .....  
 .....

Answer ..... (1 mark)

- (b) There are 320 girls in the school who are vegetarian.  
 How many students are there in the school altogether?

.....  
 .....  
 .....

Answer ..... students (2 marks)

4 (a) Expand and simplify

$$5(2a - c) + 4(3a + 2c)$$

.....  
.....

Answer ..... (2 marks)

(b) Solve

$$3(x - 2) = 5x - 5$$

.....  
.....  
.....  
.....

Answer  $x =$  ..... (3 marks)

(c) Solve

$$3x + 7 < 1$$

.....  
.....  
.....

Answer ..... (2 marks)

**TURN OVER FOR THE NEXT QUESTION**

Turn over 

- 5 (a) Liquid is poured at a steady rate into the bottle shown in the diagram.

As the bottle is filled, the height,  $h$ , of the liquid in the bottle changes.

Which of the five graphs below shows this change?

Give a reason for your choice.

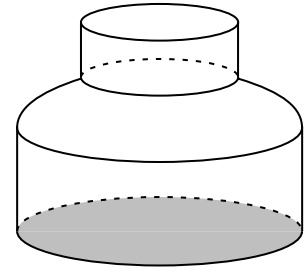

Graph A

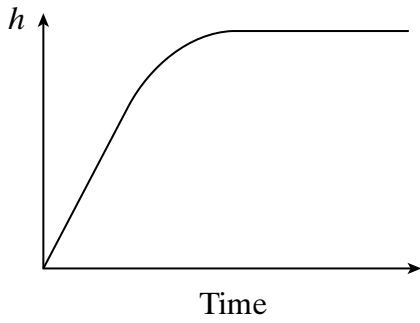

Graph B

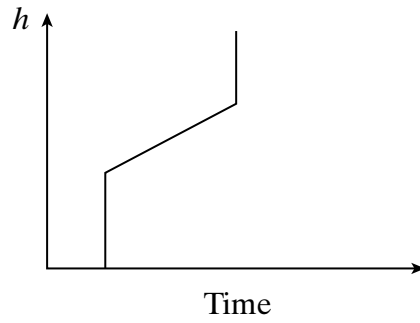

Graph C

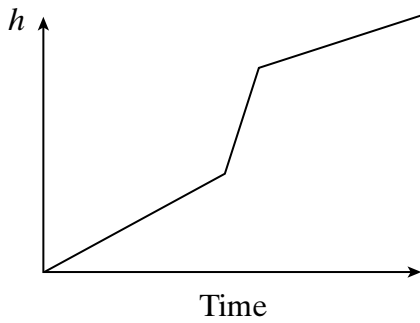

Graph D

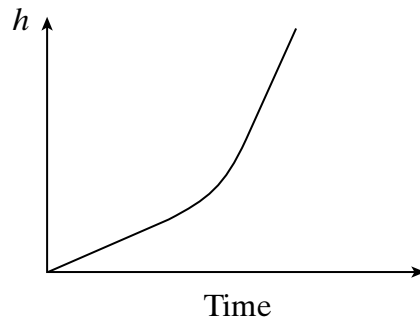

Graph E

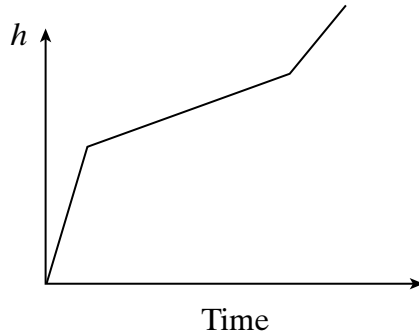

Graph .....

Reason .....

.....

(2 marks)

- (b) Liquid is poured at a steady rate into another container.  
The graph shows how the height,  $h$ , of the liquid in this container changes.  
Sketch a picture of this container.

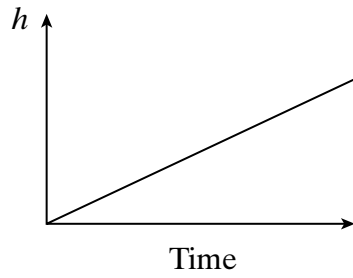

(1 mark)

6 Solve the equations

(a)  $\frac{12 - y}{3} = 5$

.....

.....

.....

.....

Answer  $y = \dots\dots\dots$  (3 marks)

(b)  $\frac{2x + 1}{4} + \frac{4x + 1}{6} = 1$

.....

.....

.....

.....

.....

.....

.....

Answer  $x = \dots\dots\dots$  (4 marks)

Turn over

- 7 The diagram shows a circle with centre  $O$  and radius 2.5 cm.  
 $TA$  is a tangent to the circle, of length 6 cm.  
The line from  $A$  to the centre  $O$  of the circle cuts the circumference at  $B$ .

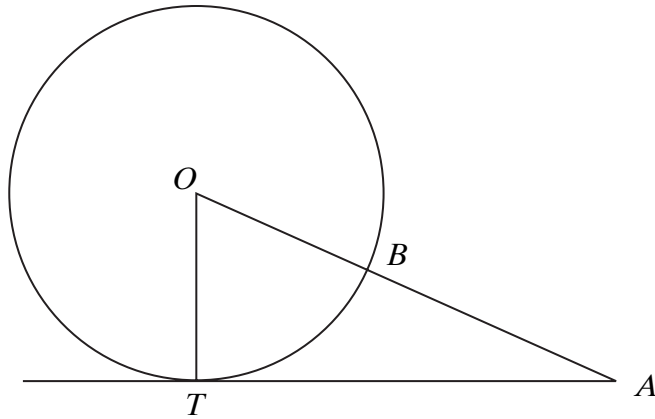

Calculate the length of  $AB$ .

.....

.....

.....

.....

.....

Answer ..... cm (4 marks)

- 8 (a)  $ABC$  is a right-angled triangle.  
 $AB = 5.1$  cm  
 $\angle CAB = 48^\circ$

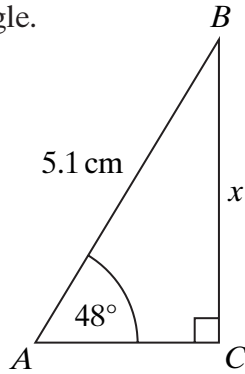

Not drawn accurately

Find the length of  $BC$  (marked  $x$  in the diagram).  
 Give your answer to a suitable degree of accuracy.

.....

.....

.....

.....

.....

.....

Answer ..... cm (4 marks)

- (b)  $PQRS$  is a parallelogram.  
 $PQ = 5.1$  cm  
 $PS = 6.8$  cm  
 $\angle QPS = 48^\circ$

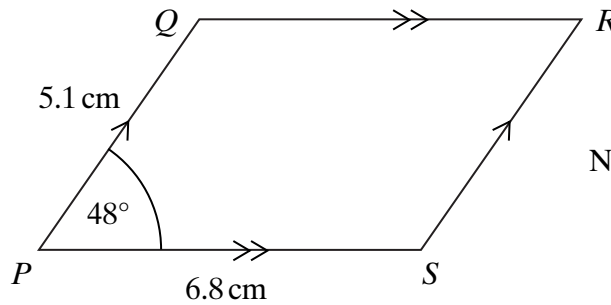

Not drawn accurately

Calculate the area of  $PQRS$ .

.....

.....

.....

.....

Answer ..... cm<sup>2</sup> (2 marks)

Turn over ►

9 Show that the sum of **any** three consecutive integers is always a multiple of 3.

.....

.....

.....

.....

.....

.....

(3 marks)

10 Make  $t$  the subject of the formula  $u = \frac{t}{3} + 5$

.....

.....

.....

.....

.....

.....

Answer  $t =$  ..... (2 marks)

11 (a) Write 7 billion as a number in standard form.

1 billion = 1000 million

.....  
.....

Answer ..... (1 mark)

(b) Write the number  $4.5 \times 10^{-3}$  as an ordinary number.

.....  
.....

Answer ..... (1 mark)

(c) Find the value of  $(2.7 \times 10^3) \div (3.375 \times 10^5)$   
Give your answer in standard form.

.....  
.....  
.....

Answer ..... (2 marks)

**TURN OVER FOR THE NEXT QUESTION**

- 12 Brian and George played 40 games of golf.  
The cumulative frequency diagram shows information about Brian's scores.  
The box plot shows information about George's scores.

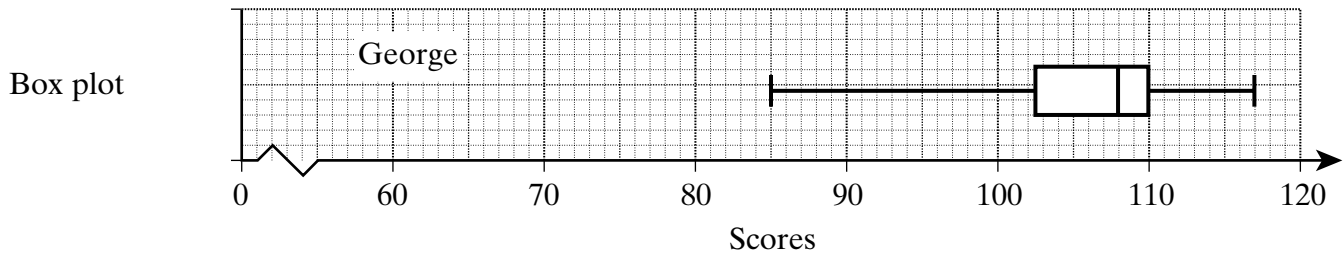
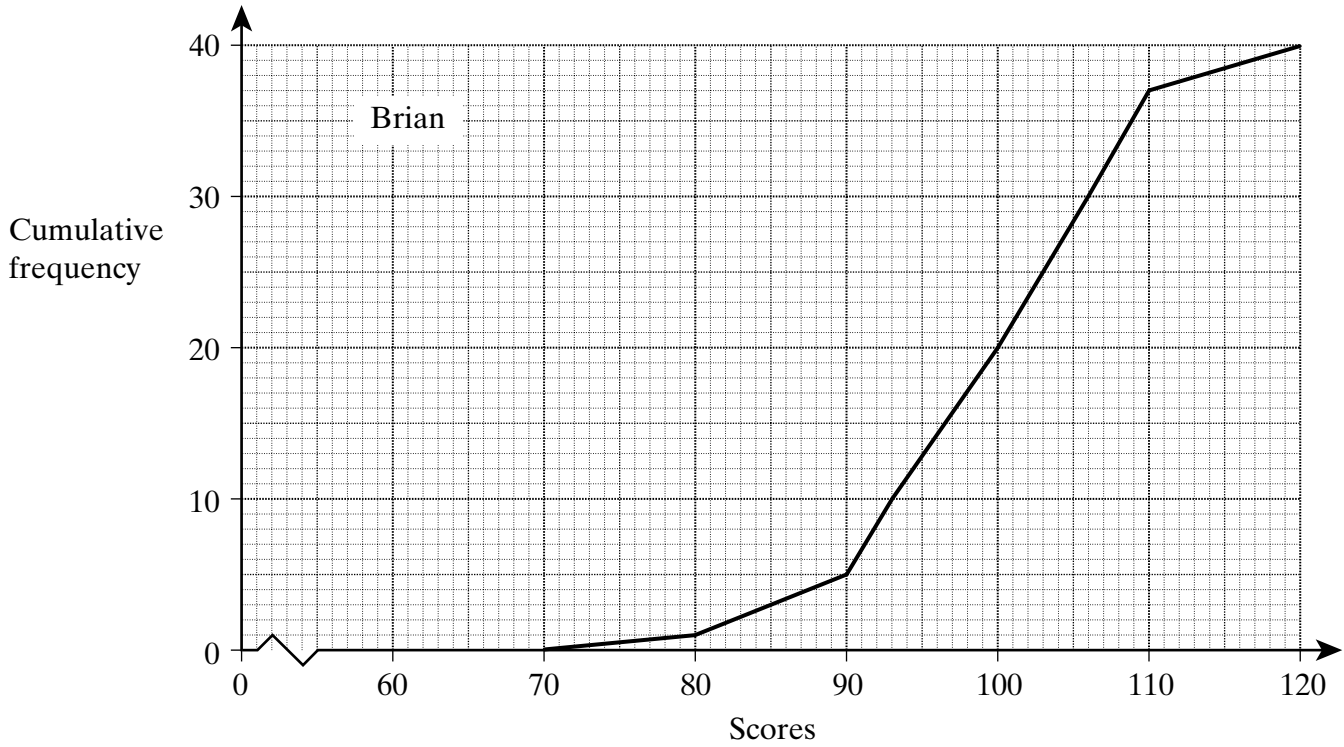

(a) Showing your method clearly, find

(i) Brian's median score

.....

.....

Answer ..... (1 mark)

(ii) Brian's inter-quartile range.

.....

.....

.....

Answer ..... (2 marks)

(b) Use the cumulative frequency diagram and the box plot to answer the following.

- (i) Which player is the more consistent in his scoring?  
Give a reason for your choice.

.....  
.....  
(1 mark)

- (ii) The winner of a game of golf is the player who has the lowest score.  
Who do you think is the better player?  
Give a reason for your choice.

.....  
.....  
(1 mark)

**13** Write  $0.3\dot{1}\dot{5}$  as a fraction in its simplest form.

.....  
.....  
.....  
.....  
.....  
.....  
.....

Answer ..... (3 marks)



Turn over

14 Solve the equation

$$x^2 - 10x - 5 = 0$$

Give your answers to 2 decimal places.

.....

.....

.....

.....

.....

.....

.....

Answer ..... (3 marks)

15  $ABCD$  is a rectangle with length 25 cm and width 10 cm.

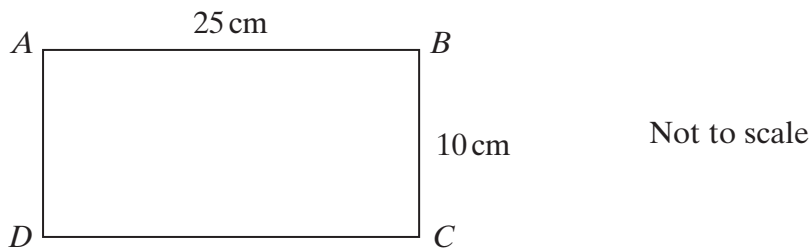

The length of the rectangle is increased by 10%.  
The width of the rectangle is increased by 20%.  
Find the percentage increase in the area of the rectangle.

.....

.....

.....

.....

.....

.....

Answer ..... % (3 marks)

16 In triangle  $ABC$ ,  $AB = 11$  cm,  $BC = 9$  cm and  $CA = 10$  cm.

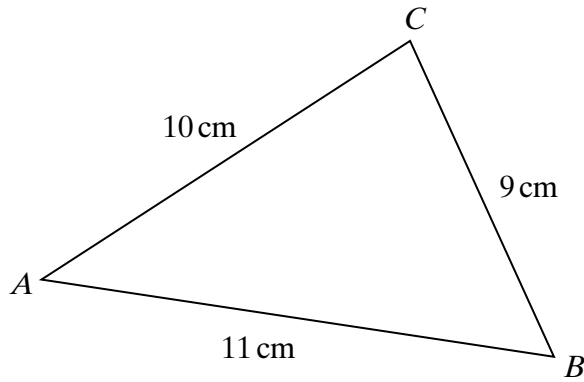

Not to scale

Find the area of triangle  $ABC$ .

.....

.....

.....

.....

.....

.....

.....

.....

.....

.....

.....

Answer .....  $\text{cm}^2$  (5 marks)



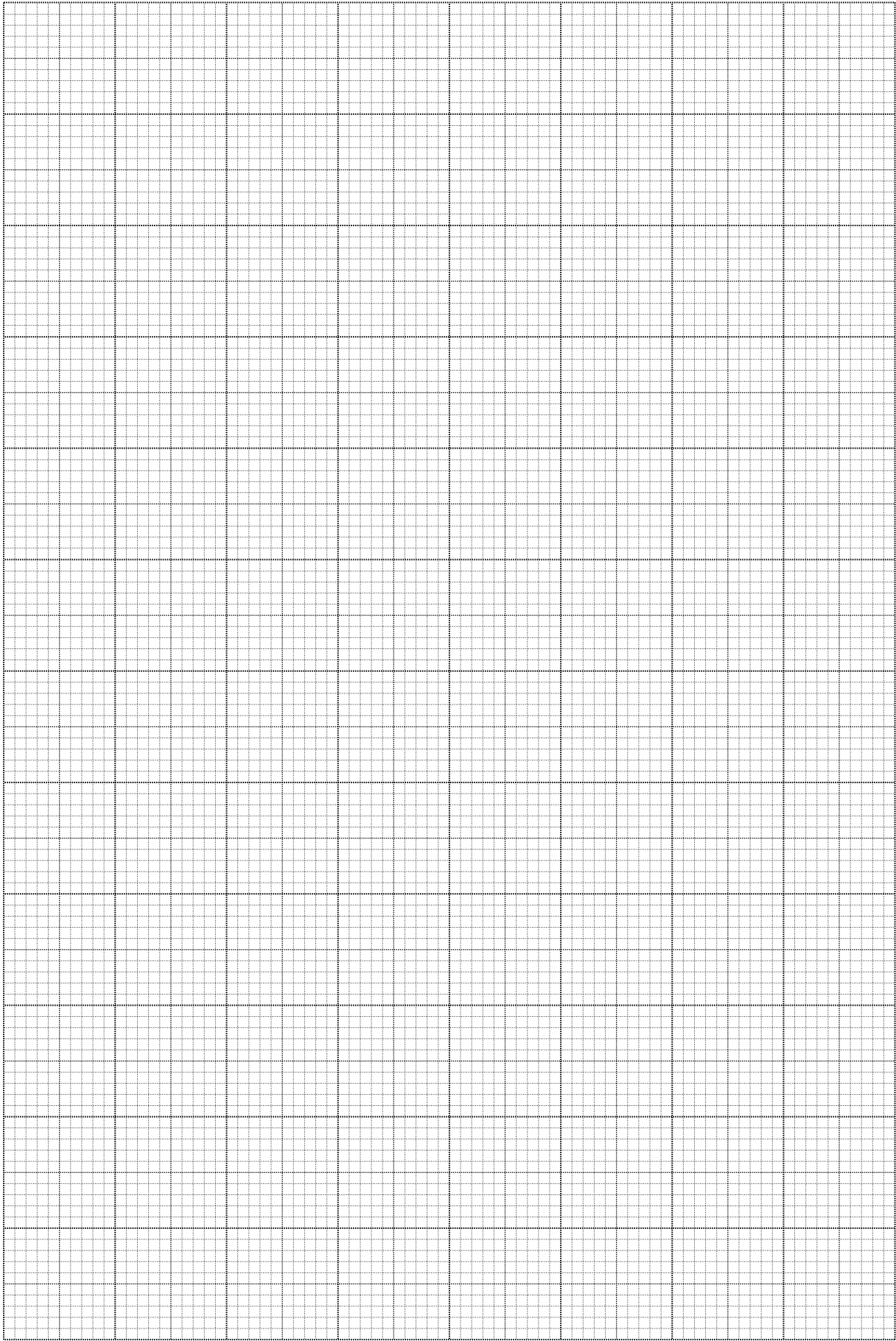

Turn over ►

18 A solid cube has a square hole cut through horizontally and a circular hole cut through vertically.

Both holes are cut centrally in the appropriate faces.

The dimensions of the cube and the holes are as shown in the diagram.

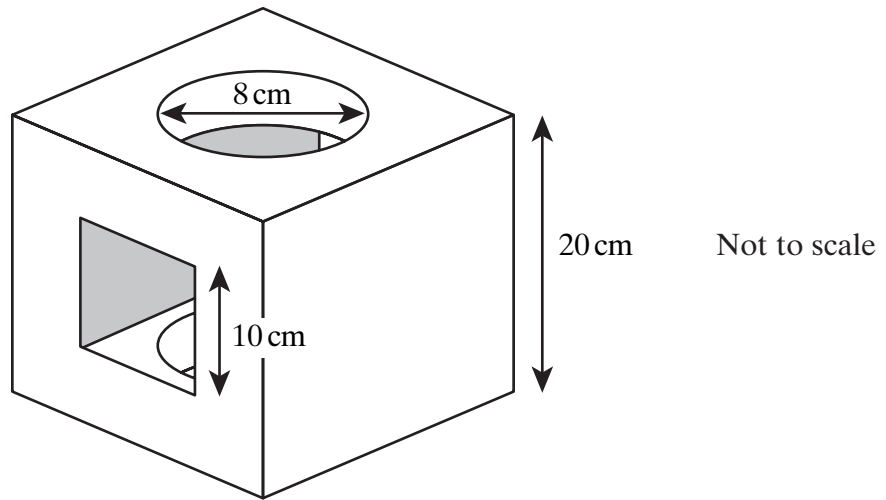

Calculate the volume remaining after the holes have been cut.

.....

.....

.....

.....

.....

.....

.....

.....

.....

.....

Answer ..... (5 marks)

**19** The government wants to survey students studying science at University about their views on becoming teachers.

They decide to survey science students at Surrey University.

2371 students do science at Surrey University.

The cumulative percentage table of students doing each science is

Geology	Physics	Chemistry	Biology
0%	18%	42%	66%

Cumulative percentage

(a) The government decide to do a 10% stratified sample.  
Write down the numbers from each category that they should sample.

.....

.....

.....

.....

Geology	Physics	Chemistry	Biology

(3 marks)

(b) Give one other factor they should take into account when selecting the sample to ensure an unbiased sample.

.....

.....

.....

(1 mark)

**20** Solve the equation  $\frac{1}{x+1} + \frac{5x}{x-2} = 3$

.....  
.....  
.....  
.....  
.....  
.....  
.....  
.....  
.....  
.....  
.....  
.....  
.....  
.....  
.....

Answer ..... (5 marks)

**21** A boy runs 50 metres at a speed of 5 m/s.  
Both values are measured to an accuracy of one significant figure.  
What is the least possible time taken?

.....  
.....  
.....  
.....  
.....  
.....  
.....  
.....  
.....

Answer ..... seconds (3 marks)

22 Make  $x$  the subject of the formula

$$y = \frac{3x + 4}{x - 3}$$

.....

.....

.....

.....

.....

.....

.....

.....

.....

Answer  $x =$  ..... (4 marks)

23 A bag contains 8 balls.  
5 are black and 3 are white.



A ball is taken out of the bag at random and **not** replaced.  
Another ball is taken out of the bag at random.  
What is the probability that both of the balls are the same colour?

.....

.....

.....

.....

.....

.....

.....

.....

.....

.....

Answer ..... (3 marks)

**Turn over** ▶

**24** The grid on the opposite page shows the graphs of

$$y = x^2 - x - 6$$

and

$$y = x + 2$$

(a) Deduce the coordinates of the minimum point of the graph  $y = x^2 - x - 12$

.....

.....

Answer ( ..... , ..... ) (1 mark)

(b) Find the quadratic equation whose solutions are the  $x$ -coordinates of the points of intersection of  $y = x^2 - x - 6$  and  $y = x + 2$ .

.....

.....

.....

.....

.....

Answer ..... (2 marks)

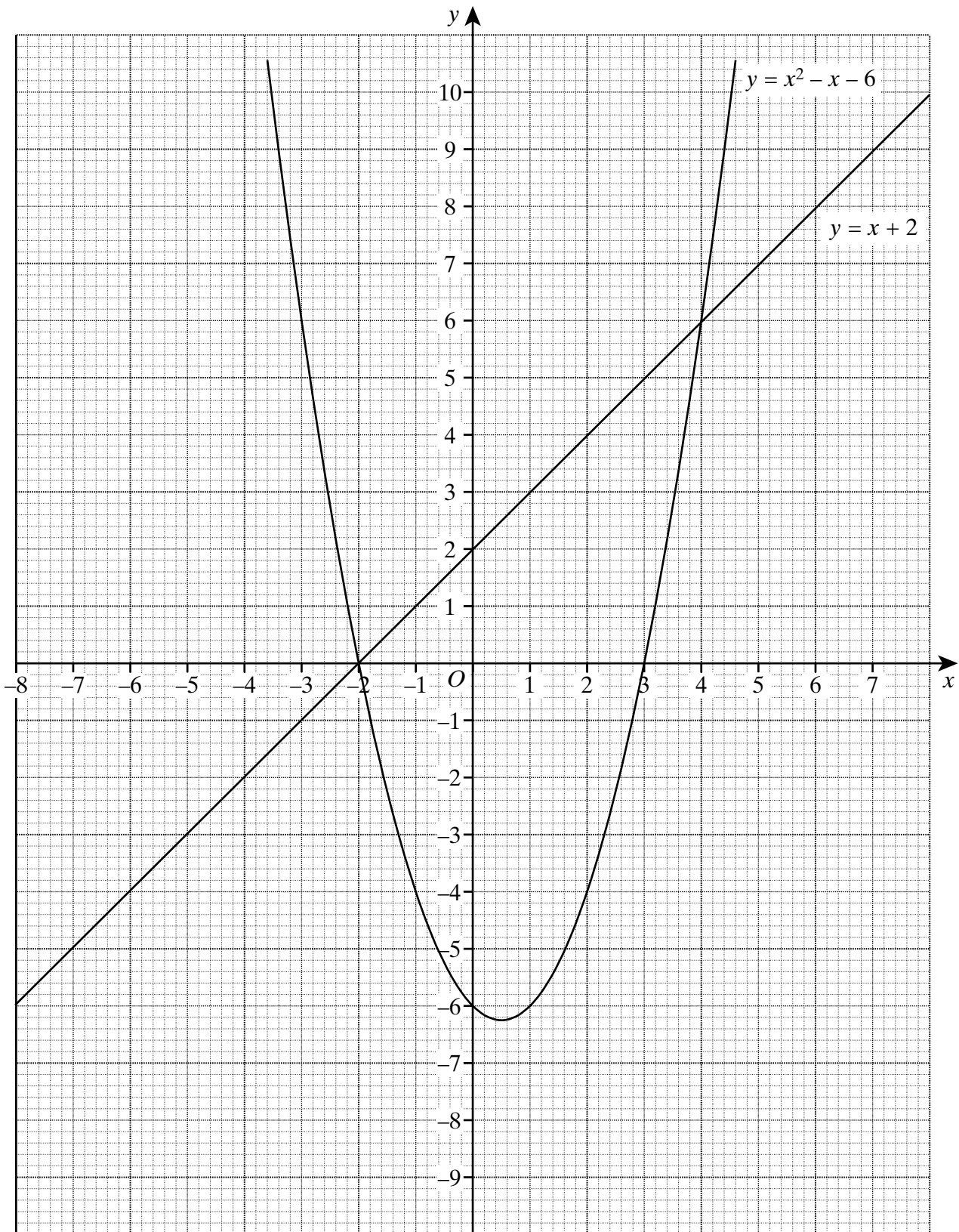
Turn over 

- 25 A square-based pyramid has a base of edge 5 cm.  
The vertex of the pyramid is directly over the midpoint of the base.  
The volume of the pyramid is  $100 \text{ cm}^3$ .

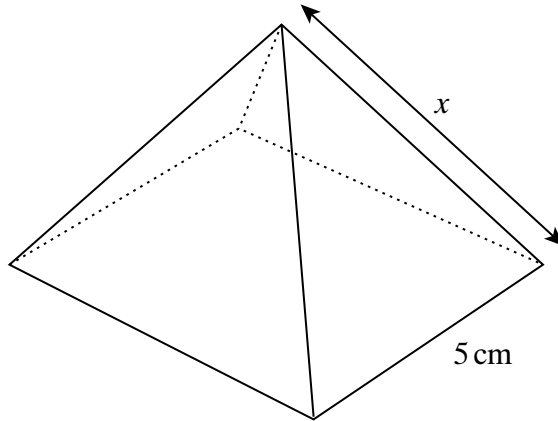

Volume of a pyramid =  $\frac{1}{3} \times \text{base area} \times \text{height}$ .

Find the length of the slant edge of the pyramid (marked  $x$  in the diagram).

.....

.....

.....

.....

.....

.....

.....

.....

.....

.....

.....

.....

.....

.....

.....

.....

.....

.....

.....

.....

.....

Answer ..... cm (5 marks)

**END OF QUESTIONS**