

Surname						Other Names					
Centre Number						Candidate Number					
Candidate Signature											

Leave blank

General Certificate of Secondary Education
June 2003



MATHEMATICS (SPECIFICATION A) 3301/2H
Higher Tier
Paper 2 Calculator

H

Tuesday 10 June 2003 9.00 am to 11.00 am

<p>In addition to this paper you will require:</p> <ul style="list-style-type: none"> • a calculator • mathematical instruments. 	
---	--

For Examiner's Use	
Pages	Mark
3	
4 – 5	
6 – 7	
8 – 9	
10 – 11	
12 – 13	
14 – 15	
16 – 17	
18 – 19	
20	
TOTAL	
Examiner's Initials	

Time allowed: 2 hours

Instructions

- Use blue or black ink or ball-point pen. Draw diagrams in pencil.
- Fill in the boxes at the top of this page.
- Answer **all** questions in the spaces provided.
- Do all rough work in this booklet.
- If your calculator does not have a π button, take the value of π to be 3.14 unless otherwise instructed in the question.

Information

- The maximum mark for this paper is 100.
- Mark allocations are shown in brackets.
- Additional answer paper, graph paper and tracing paper will be issued on request and must be tagged securely to this answer booklet.
- You are expected to use a calculator where appropriate.

Advice

- In all calculations, show clearly how you work out your answer.

Formulae Sheet: Higher Tier

You may need to use the following formulae:

Volume of prism = area of cross section \times length

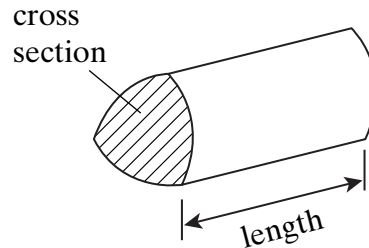

Volume of sphere = $\frac{4}{3} \pi r^3$

Surface area of sphere = $4 \pi r^2$

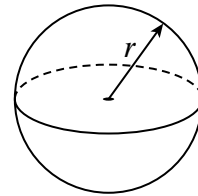

Volume of cone = $\frac{1}{3} \pi r^2 h$

Curved surface area of cone = $\pi r l$

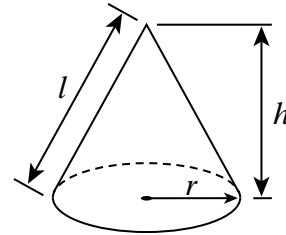

In any triangle ABC

Area of triangle = $\frac{1}{2} ab \sin C$

Sine rule $\frac{a}{\sin A} = \frac{b}{\sin B} = \frac{c}{\sin C}$

Cosine rule $a^2 = b^2 + c^2 - 2bc \cos A$

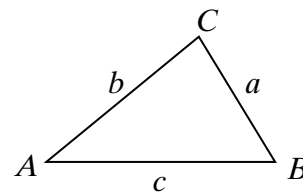

The Quadratic Equation

The solutions of $ax^2 + bx + c = 0$, where $a \neq 0$, are given by

$$x = \frac{-b \pm \sqrt{b^2 - 4ac}}{2a}$$

Answer **all** questions in the spaces provided.

- 1 A support for a flagpole is attached at a height of 3m and is fixed to the ground at a distance of 1.2m from the base.

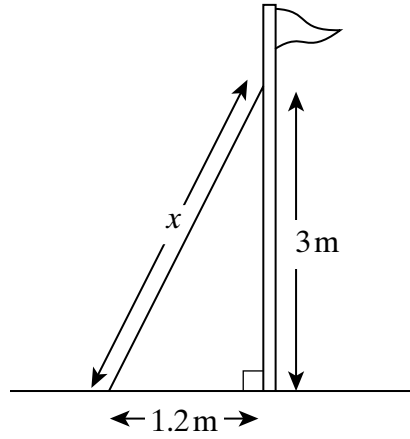

Not to scale

Calculate the length of the support (marked x on the diagram).

.....

.....

.....

.....

.....

.....

.....

.....

Answer m (3 marks)

- 2 Mrs Jones inherits £12 000. She divides the £12 000 between her three children Laura, Mark and Nancy in the ratio 7 : 8 : 9, respectively. How much does Laura receive?

.....

.....

.....

.....

Answer £ (2 marks)

Turn over ▶

- 3 Parveen is using trial and improvement to find a solution to the equation

$$x^3 + 7x = 30$$

This table shows her first two trials.

x	$x^3 + 7x$	Comment
2	22	Too small
3	48	Too big

Continue the table to find a solution to the equation.

Give your answer to 1 decimal place.

Answer (3 marks)

- 4 In 2003 the State Pension was increased by 2% to £78.03
What was the State Pension before this increase?

.....

.....

.....

.....

Answer £ (3 marks)

5 Jane records the times taken by 30 pupils to complete a number puzzle.

Time, t (minutes)	Number of pupils
$2 < t \leq 4$	3
$4 < t \leq 6$	6
$6 < t \leq 8$	7
$8 < t \leq 10$	8
$10 < t \leq 12$	5
$12 < t \leq 14$	1

(a) Calculate an estimate of the mean time taken to complete the puzzle.

.....

.....

.....

.....

.....

Answer minutes (4 marks)

(b) Which time interval contains the median time taken to complete the puzzle?

.....

.....

Answer (1 mark)

- 6 *ABC* is a right-angled triangle.
 $BC = 125$ m.
 Angle $CAB = 33^\circ$.

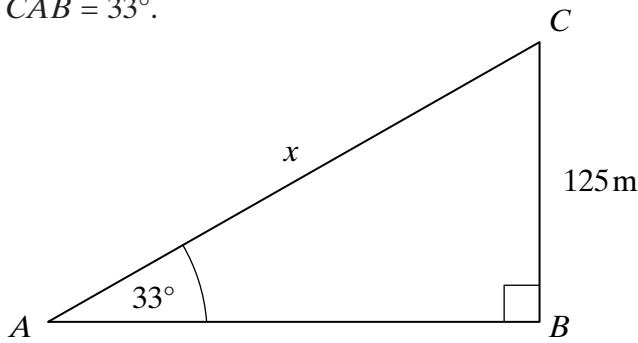

Not drawn accurately

Find the length of AC (marked x in the diagram).
 Give your answer to an appropriate degree of accuracy.

.....

.....

.....

.....

.....

.....

Answer m (4 marks)

- 7 (a) (i) Use your calculator to find $\sqrt{28.9^2 - 9.24^2}$
 Give **all** the figures in your calculator display.

.....

.....

Answer (1 mark)

- (ii) Write your answer to 3 significant figures.

.....

Answer (1 mark)

- (b) Find the value of $(3.18 \times 10^5) \times (4.25 \times 10^3)$.
 Give your answer in standard form.

.....

.....

Answer (2 marks)

8 (a) Solve the equation $\frac{23 - 2x}{5} = 3$

.....

Answer $x =$ (3 marks)

(b) Solve the inequality $3x + 8 < 29$

.....

Answer (2 marks)

9 Triangle P is an enlargement of the shaded triangle.

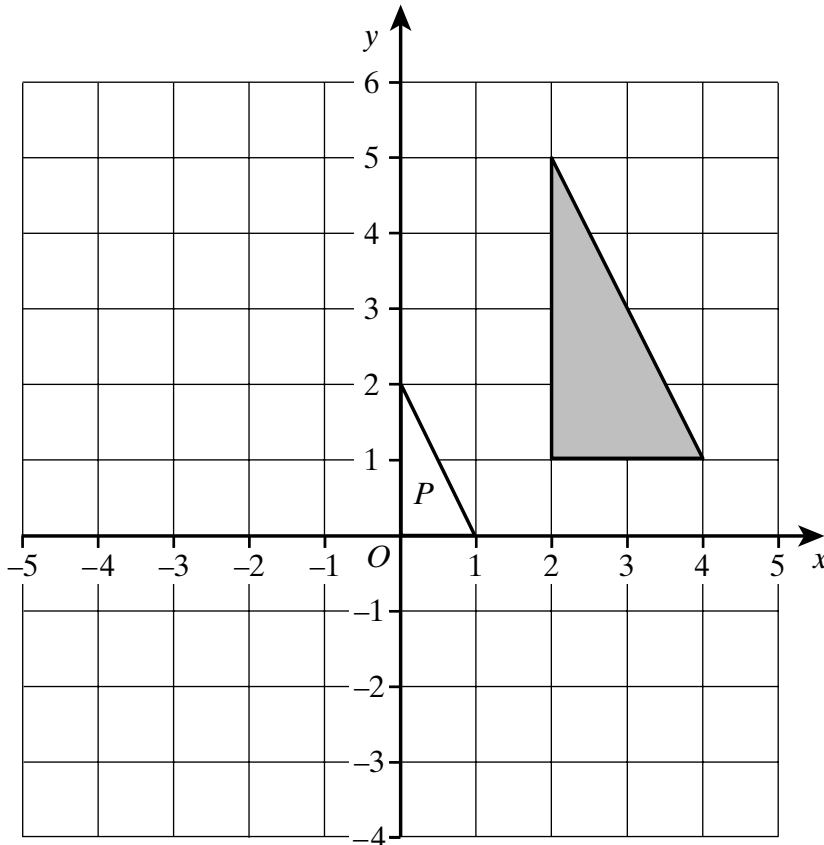

(a) What is the scale factor of the enlargement?

Answer (1 mark)

(b) What is the centre of enlargement?

Answer (..... ,) (1 mark)

Turn over ►

10 (a) (i) Factorise completely $2a^2 - a$

.....

Answer (2 marks)

(ii) Find the value of $2a^2 - a$ when $a = -4.5$

.....

Answer (2 marks)

(b) Expand and simplify $(4x - 3)(x + 5)$

.....

Answer (3 marks)

(c) Simplify

(i) $x^5 \times x^{-2}$

.....

Answer (1 mark)

(ii) $y^5 \div y^{-2}$

.....

Answer (1 mark)

11 Make x the subject of the formula

$$w = x^2 + y$$

.....

.....

.....

.....

Answer $x =$ (2 marks)

12 The length of time, in minutes, of 40 telephone calls was recorded.
A cumulative frequency diagram of this data is shown on the grid below.

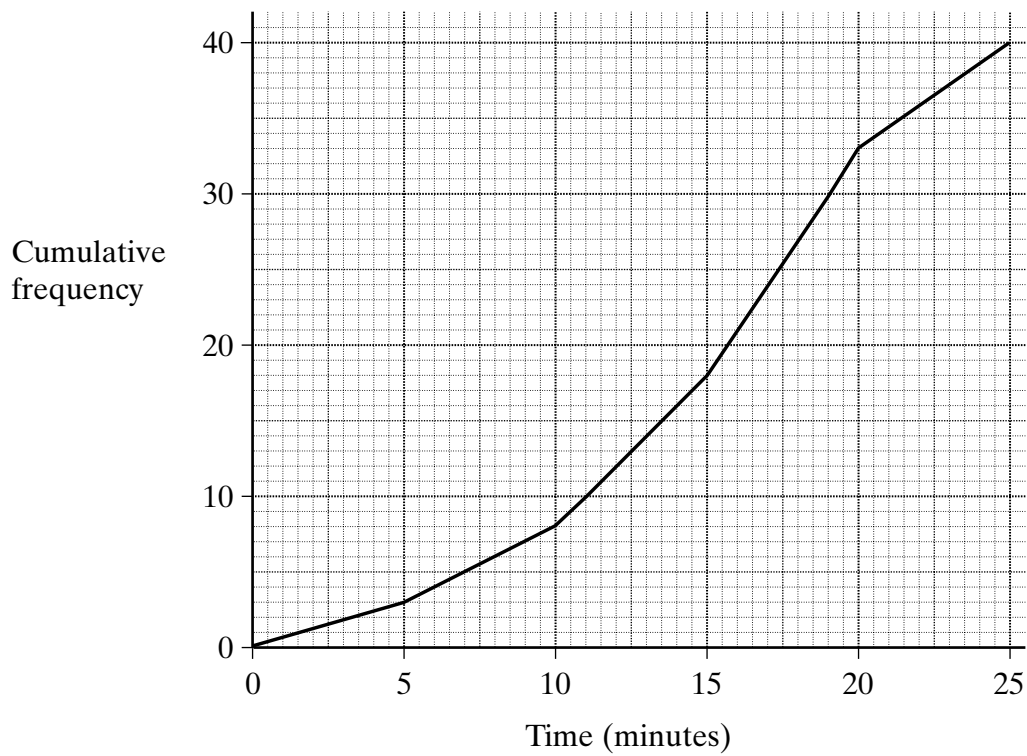

Use the diagram to find the limits between which the middle 50% of the times lie.

.....

.....

Answer minutes and minutes (2 marks)

13 The region R is shown shaded below.

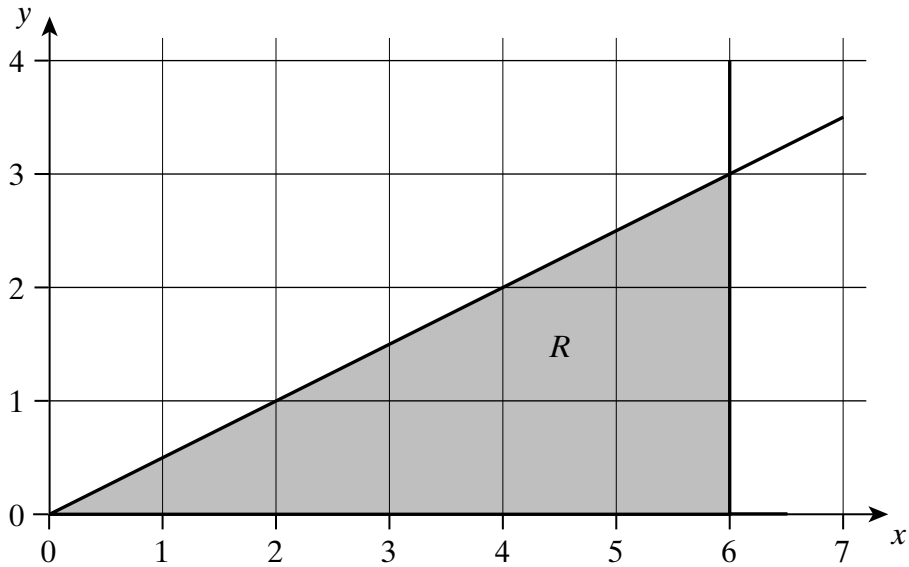

Write down three inequalities which together describe the shaded region.

.....

.....

.....

.....

Answer

.....

..... (3 marks)

14 Express $0.\dot{4}\dot{8}$ as a fraction in its simplest form.

.....

.....

.....

.....

Answer (2 marks)

- 15 In the diagram, the lines AC and BD intersect at E .
 AB and DC are parallel and $AB = DC$.

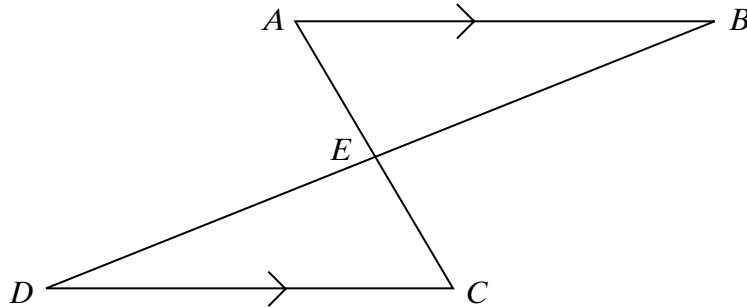

Prove that triangles ABE and CDE are congruent.

.....

.....

.....

.....

.....

.....

(4 marks)

TURN OVER FOR THE NEXT QUESTION

- 16 The table shows the percentage of men in Britain who smoked.
The data was recorded every two years from 1974 to 1988.

Year	1974	1976	1978	1980	1982	1984	1986	1988
%	50	46	45	42	38	36	35	33

- (a) Calculate the first value of the three-point moving average for these data.

.....
.....

Answer (2 marks)

- (b) The graph shows the three-point moving average for the percentage of men who smoked, plotted every two years, from 1978.

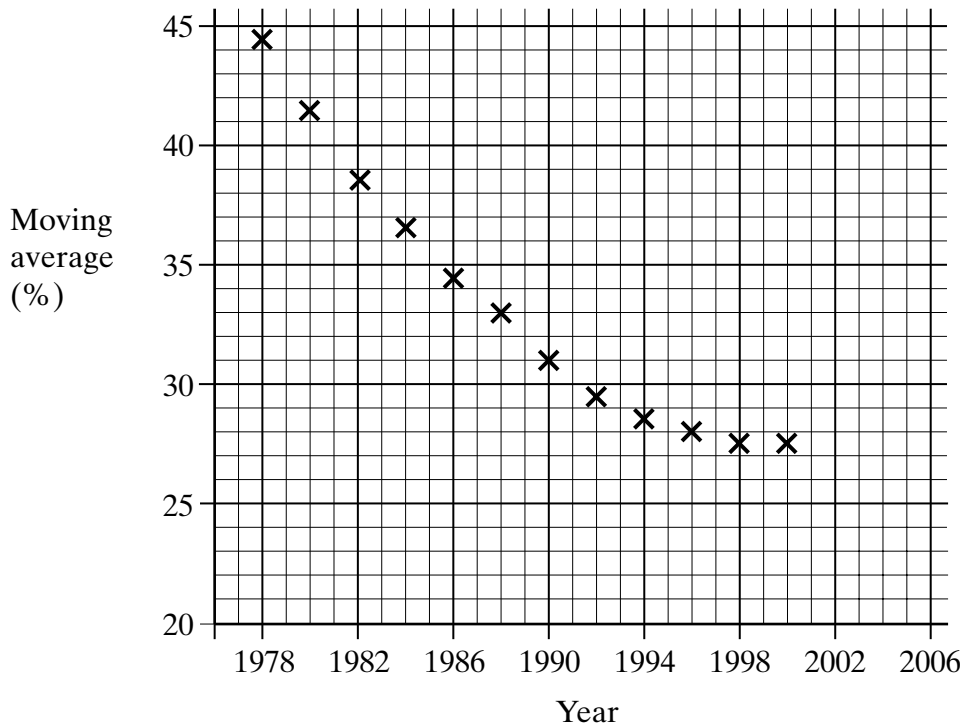

The government has set a target of reducing the percentage of male smokers to below 25% by the year 2006.

Comment on whether they will achieve this target.

Justify your answer.

.....
.....
.....
.....

(2 marks)

- (c) The government decides to carry out a survey of male smoking habits.
Give **two** factors that need to be taken into consideration when planning the survey.

Factor 1

.....

Factor 2

.....

(2 marks)

- 17 *ABCDEFGH* is a cuboid with sides of 5 cm, 5 cm and 12 cm as shown.

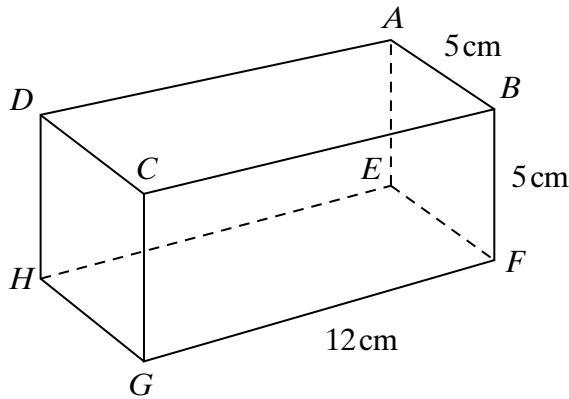

Not to scale

Calculate angle *DFH*.

.....

.....

.....

.....

.....

.....

.....

.....

.....

.....

Answer degrees (5 marks)

Turn over ▶

- 18** Two ships, *A* and *B*, leave port at 1300 hours.
 Ship *A* travels at a constant speed of 18 km per hour on a bearing of 070° .
 Ship *B* travels at a constant speed of 25 km per hour on a bearing of 152° .

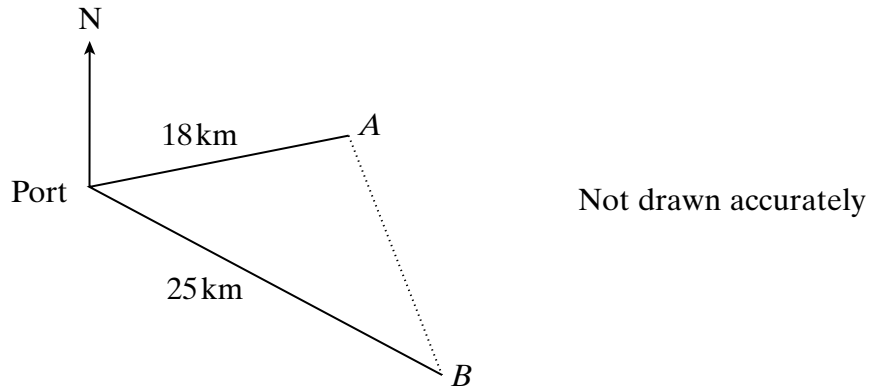

Calculate the distance between *A* and *B* at 1400 hours.

.....

.....

.....

.....

.....

.....

.....

.....

.....

Answer km (4 marks)

- 19 A thin-walled glass paperweight consists of a hollow cylinder with a hollow cone on top as shown.
The paperweight contains just enough sand to fill the cylinder.

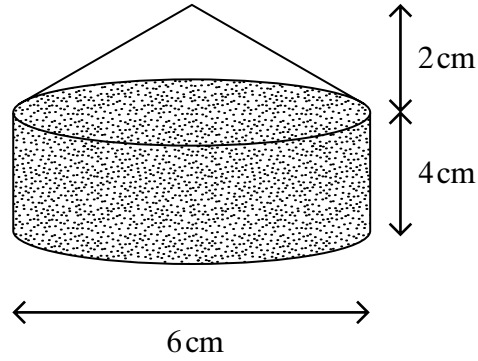

The paperweight is now turned upside down.

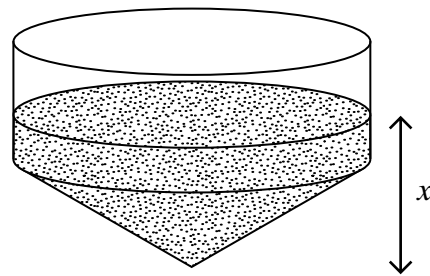

Calculate the depth of the sand, (marked x in the diagram).

.....

.....

.....

.....

.....

.....

.....

.....

.....

.....

.....

Answer cm (5 marks)

Turn over ►

20 (a) Expand and simplify

$$(x + 4)^2$$

.....
.....
.....

Answer (2 marks)

(b) The diagram shows the circle $x^2 + y^2 = 36$ and the line $y = x + 4$.
The line and the circle intersect at the points A and B .

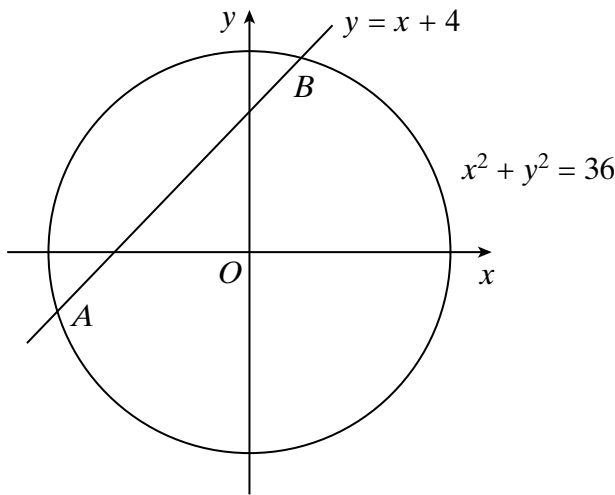

Not drawn accurately

Show that the x -coordinates of A and B are given by the solutions to the equation

$$x^2 + 4x - 10 = 0$$

.....
.....
.....
.....
.....

(2 marks)

- (c) Solve the equation $x^2 + 4x - 10 = 0$.
 Give your answers to 2 decimal places.
 You **must** show your working.

.....

.....

.....

.....

.....

.....

Answer (3 marks)

- 21 Two similar bottles are shown below.
 The smaller bottle is 20 cm tall and holds 480 ml of water.
 The larger bottle is 30 cm tall.

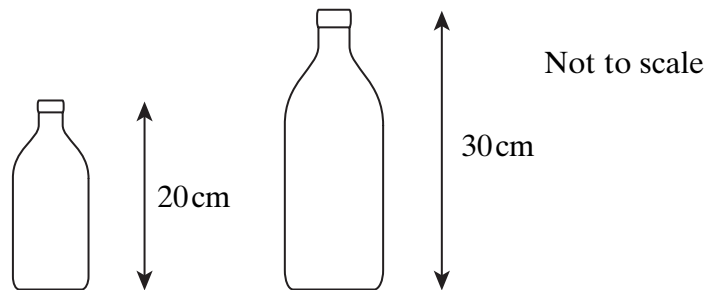

How much water does the larger bottle hold?

.....

.....

.....

Answer (3 marks)

22 Solve the equation $\frac{x}{x+1} - \frac{2}{x-1} = 1$

.....

.....

.....

.....

.....

.....

.....

.....

.....

.....

.....

Answer (5 marks)

23 Make r the subject of the formula

$$r - 3 = \pi(t - 2r)$$

.....

.....

.....

.....

.....

.....

Answer (4 marks)

24 Simplify

$$\frac{5x^2 + 14x - 3}{x^2 - 9}$$

.....

.....

.....

.....

.....

.....

.....

.....

Answer (4 marks)

TURN OVER FOR THE NEXT QUESTION

Turn over ►

25 A coffee machine dispenses 130 millilitres of black coffee into cups with a capacity of 175 millilitres. These values are accurate to 3 significant figures.

Milk is supplied in small cartons which contain 21 millilitres, accurate to the nearest millilitre.

Beryl likes milky coffee and always puts 2 cartons of milk in her coffee.



Will Beryl's cup ever overflow?

You **must** show all your working.

.....

.....

.....

.....

.....

.....

.....

.....

.....

.....

(4 marks)

END OF QUESTIONS