

Artefacts for Mathematics

Artefacts for Mathematics

A collection of things to make connected with mathematics

Note that while most of these items can be satisfactorily printed out on any basic printer, for the best results, a laser printer (working at 600 dpi) is recommended, especially for the first two items. One sheet requires a colour printer.

The “Training” Protractor

This might be useful when starting on the measurement of angles.

There can be very few teachers who have not seen pupils having difficulties with the traditional dual-scale 180° protractor. Which figure should you use? It was several experiences of this which eventually prompted the question “What if there no numbers on the protractor and the distance had to be counted off?” The result of that line of thinking led to the sheet now offered here.

After printing a master copy, use a photo-copier to print off a few onto ohp acetate sheet and then cut them out. At 10 to a sheet they must be the cheapest protractors around. If you want to give them a permanent identifier, put a class or school name in the blank space at the bottom of each protractor before doing the photo-copying.

Don’t forget, if anyone asks what it is all about, you indicate that “On your budget you couldn’t afford to buy the ones with numbers on!”

The “Navigator” Protractor

A circular 360° protractor which bears the basic markings needed for dealing with bearings.

Made just like the previous ones, at 6 to a sheet they are not quite so cheap, but for a 360° protractor, they still offer a truly economical model. Markings have been cut to a minimum for clarity of reading. Though not offering the accuracy of more sophisticated models, all the elements needed to establish the principles are there. Many will appreciate having the ‘W’ and ‘E’ markings displayed too!

The “Handy” Clinometer

To measure angles of elevation (or depression) in some practical work.

Again, this is intended to offer a cheap way of providing each member of a group with a working instrument which is accurate enough to serve as an introduction. In this case, used with care, very good results can be obtained.

Some practical points. As always with such things, it is best to have one made up beforehand so that all can see what it should look like. (“Here is one I made last night.”) The size of the small rectangle for the front sight is not crucial. The hole for the back sight should be as small as possible so long as it can be seen through. It is probably best done by experiment. Start with using a compass point and then gradually enlarging it with a pencil. When it gets too big, stick a piece of card over it and start again!

Thread is best for making the plumb-line; string is rather clumsy. Make the hole for the pivot-point small (compass point again) just to allow the thread to be passed through and knotted at the back. The length of the line and size of the plumb-bob are not crucial (within reason).

In use, it is best if the work is done in pairs. One does the sighting, while the other reads off the angle. They then change over. All differences should be reconciled before returning to the classroom!

Tower of Hanoi Puzzle

This is a well-known activity and has been written about in several books. Its one drawback for classroom use is that the usual piece of equipment is not one that is likely to be available in multiple copies. This leads to work being done by demonstration only or by individuals. The sheets provided here are intended to overcome that, making it possible for every member of the class to have a set very cheaply. It is simple to make (just some cutting and glueing) and a full classroom set does not take up much room for storage purposes. The pieces fit one inside the other.

The sets of pieces can be made to look a little more attractive in use if, first of all the sheet is photo-copied on a variety of coloured cards, and then individuals share two differently coloured cards, using one colour for the odd-numbered pieces, and the other colour for the even-numbered pieces. Each then finishes up with an attractive 2-colour tower.

So, having made it, what can be done with it?

First of all solve the puzzle as given. Possibly start with a small 'tower', say 2 or 3 pieces, and move that. Then increase the size by one more piece. And so on.

Next, how many moves does it take to move a tower? And here we mean minimum number of moves of course. How many moves for different sizes of tower? A 1-tower can be done in 1 move. A 2-tower can be done in 3 moves. A 3-tower can be done in ?? moves. And so on. Make a table. The pattern is not difficult to see. An n -tower can be done in ?? moves.

Devising a system of recording moves is worthwhile. With the positions marked and the pieces numbered there are obvious possibilities. This should throw up some ideas on the way the pieces move. It can be made clearer if, instead of using the given board, the positions are set out as the vertices of an equilateral triangle and movements are thought of as being either clockwise or anti-clockwise.

And then there are the variations.

Starting with a single tower in one position, split it into 2 towers in the other 2 positions. Perhaps with one having all the odd-numbered pieces, and the other all the even-numbered. Or split the single tower into 3 towers, say 1 & 2, 3 & 4, and 5 & 6. For this, there should be an additional rule that the bottom piece (6) must move. Always, of course, the minimum number of moves is sought.

Distribute the pieces at random, but never having a larger on top of a smaller, between the various positions, and then assemble them into a single tower. What is the worst possible case you can create for this, that is, which situation requires the most moves for re-assembly?

What happens if the number of allowed positions is increased (D and E?) and/or the number of pieces is increased?

There is a lot to be explored in the Tower of Hanoi puzzle, from just doing it, up to a full analysis, formula and proof.

The “Ten-talizer” Puzzle

This is a variation of a well-known puzzle that has been around since the beginning of the last century. It has been produced in various forms and with various titles - “The Tantalizer”, “Instant Insanity”, “Drive-U-Crazy” and so on. The object of the puzzle is explained on the sheet provided for making it. One practical point for group-work: as it is essential that complete sets of four are kept together, and they all look rather similar, individuals should be told to put their initials (or some special mark) on each of the cubes. Photo-copying them on a variety of coloured cards would also help.

One great feature of the puzzle as given here, is that it has stages, from exceedingly easy to the very difficult. The “real” puzzle is the last one (No. 5) and there is only one solution.

Puzzles of this type can be solved analytically and there are different ways of achieving this. Unfortunately, accounts of these are not easily found. One of the best was published in Chapter 7 of *Puzzles and Paradoxes* by T. H. O’Beirne (Oxford University Press 1965) but that has long been out of print.

Note that 4 different nets have been used for the cubes. This could logically lead to the question “How many different nets are possible for making a cube?”

The solution to the Ten-talizer Puzzle #5 can be found from the **trol** index page under
Index to Restricted Files
and details about obtaining the necessary password can also be found there.

MacMahon Tiles

Take a square tile. Draw in its two diagonals to divide it into 4 compartments, each being a right-angled isosceles triangle. Each of these compartments **must** be coloured in and there are 3 colours available (red, yellow and blue). A tile may have as many, or as few colours (3, 2 or 1) as you like. How many *different* tiles can be made? Remember, when considering *different* tiles, that a tile may be turned around but **not** over. How can you ensure that every possible *different* tile has been found, and that none has been found twice?

There are 24 *different* tiles possible under the conditions stated. They are shown on the sheet headed MacMahon Tiles and are named after the mathematician Major P A MacMahon who was working in the earlier part of the last century, and who specialised in combinatorial theory.

Having discovered, and made a set, they are admirable for some mathematical jig-saw puzzle work. Try to arrange them into a rectangle such that all touching edges match in colour. Arrange them into a 6 by 4 rectangle in which, not only do all touching edges match in colour, but the entire border edge is the same colour all the way around. This is only possible for a 6 by 4 and, though it might seem a little difficult at first, take heart, there are over 12,000 different solutions possible. A blank grid is included here on which pupils could stick their own solution. A printable solution is available in the same place as the Ten-talizer solution mentioned above.

Once again, in the classroom situation, sets should be identified (with initials on the back)

Similar work can be done with an equilateral triangle. Divide it into 3 compartments by drawing lines from each vertex to the orthocentre (the point where its 3 perpendiculars cross). Use 4 colours. Once again 24 different tiles can be made. These can be arranged to form a hexagon with touching edges matching and with a single colour around the border.

The Reaction Timer Drop Tester

This gadget leads to a piece of work which is both informative and entertaining.

First it needs to be made up in sufficient quantities so that pupils can have one each. It is best printed on card, though a decent quality paper is capable of producing reasonable results. As a check on accuracy, the left-hand strip should be 260 mm (10.24 inches) in length, but a variation of a few millimetres is of no consequence.

It is easy enough to make, just cutting out two strips and glueing them together. However, some thought should be given as to how these are to be used. If they are going to be taken out of the classroom for work to be done elsewhere (say at home) then their length and fragility makes them rather awkward to transport with care. Consider making them with a “sellotape” hinged joint rather than the more solid variety suggested in the instructions.

Usage is simple, and one demonstration should be adequate for anyone. Work in pairs. One is the ‘tester’ and the other is the ‘subject’. The tester holds the strip against the wall by pressing it at the top. The subject holds one of his/her fingers pointing at, but not touching, the zero point. The tester releases the holding-pressure and the subject ‘stabs’ at the strip to stop it falling. The ‘reaction time’ of the subject can then be read off on the strip - provided it is between one-twentieth and nearly one-third of a second.

Given a ‘free for all’ with pupils working in pairs is fun (for a while) with various strategies emerging from both the tester and the subject to ‘improve’ their different goals. The tester usually wants to make the times longer, the subject wants to make them smaller! The need for some standardised rules should become apparent. Also, most probably, the cry will go up to determine who is the ‘fastest gun’.

Then it is possible to settle down to some research. The form this might take is very variable. Pupils could be left to do their own, in or out of the classroom. Or they might be set to work in groups, with each group focussing on a particular aspect. Or each pupil could be given a pre-printed form to collect data on as wide a variety of people as possible, and the whole lot brought together for purposes of analysis. How do the results get displayed?

Some suggestions for possible investigations are

- Is there a sex difference?
- Do reaction times depend upon the hand used?
- Does age make a difference?
- Does time of day make a difference?
- Can people ‘learn’ or improve with practice?
- Are games-players quicker than non-games players?
- What about trying it with the subject blindfolded (the tester calls “Go”)
- How do results from a ‘self-test’ compare with being tested by someone else?

So what is the point of it all?

One simple example of where it matters is in driving. A car moving at 30 mph travels 44 feet in 1 second. A reaction time of 0.25 seconds means the car has moved 11 feet before the driver has actually applied the brakes, and then there is the ‘stopping distance’ to be added on. (These stopping distances for various speeds are given in the *Highway Code* so it is worth having that to hand.) And what about racing cars, or aeroplanes?

Some may wish to know the mathematics behind the markings on the strip. For a body starting from rest, accelerating solely under the action of gravity, and ignoring air-resistance, the distance travelled is given by $\frac{1}{2}gt^2$

g is the rate of acceleration due to gravity and taken as 980.665 cm/sec² or 386.09 inches/sec²

Should someone ask if the weight of the Tester makes any difference, do not discourage them from experimenting. Even Galileo had to start with those first thoughts.

Multiplication Methods

This topic is frequently suggested as being historically interesting in its own right, as well as offering some valuable insights into working with numbers. For those interested, words and phrases associated with this topic are

- Russian peasant method
- Vedic mathematics
- Gelosia multiplication
- Finger multiplication
- Using quarter-squares
- Using triangle numbers
- Logarithms
- Nomograms

In this unit, 3 items (of historical interest) are provided which enable multiplication to be done mechanically. The first two are

- Napier's Rods
- Genaille's Rods

Little needs to be said about them here, since they are well covered in the accompanying notes on how to use them. Perhaps the point should be made that, though they only multiply by a single digit, it is quite sufficient for any size of multiplier provided the user understands how to break it up into its separate units, tens, hundreds etc. In fact, once the rods have been set up, it is relatively easy to read off the different number lines that are needed for the final addition sum. No work has been provided here for use with these.

The slide Rule

This instrument is particularly interesting as, in its time, it was as important a tool as the electronic calculator is today. Though a slide rule is easy to use in principle, it poses two problems for those whose ability to work with numbers is less than good. One is the need to be able to estimate the size of the answer so as to put the decimal point in the correct place.

The other difficulty is the ability required to cope with the different sub-scales used within any single major scale. This latter arises from the uneven nature of the divisions over the length of the major scale. Typically, the 1 to 2 may be divided into a hundred parts, the 2 to 5 into fifty, and the 5 to 10 into twenty parts. The model offered here uses only two sizes of sub-division (20 and 10 parts) but even that simplification will prove difficult for some. Previous discussion using an enlarged version on an ohp slide might help.

There is a wealth of material available from the Web on this topic and an excellent starting-point is

www.sliderule.ca/intro.htm

Brief Chronology

- 1614** Napier introduced logarithms to assist with multiplication. This required numbers to be looked up in tables, added together, and the answer found by using the table 'in reverse'
- 1620** Edmund Gunter made a ruler, marked from 1 to 10, but with the divisions scaled logarithmically. This allowed the numbers to be measured, with a pair of dividers, and placed end to end, so the final end-point provided the answer which could be read off on the ruler.
- 1621** William Oughtred made two copies of Gunter's ruler and, running them side by side (just like a modern slide rule) disposed with the need for any work with dividers.

Many small improvements were made over the following years until

- 1850** Amedee Mannheim produced the design which became the 'standard' over the next 100+ years, until it was displaced by the electronic calculator. It was he who named the principal scales D and C.

Over time, the slide rule has been produced in many shapes: circular, cylindrical, helical; and for all manner of special purposes in different trades and professions. But one principle that underlies all of them is the idea of a logarithmic scale.

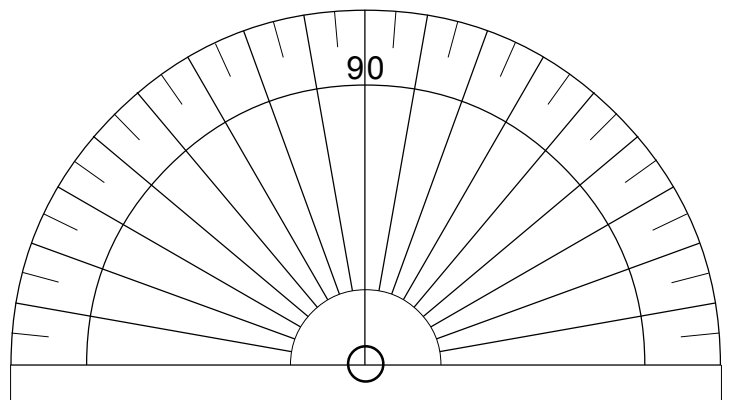
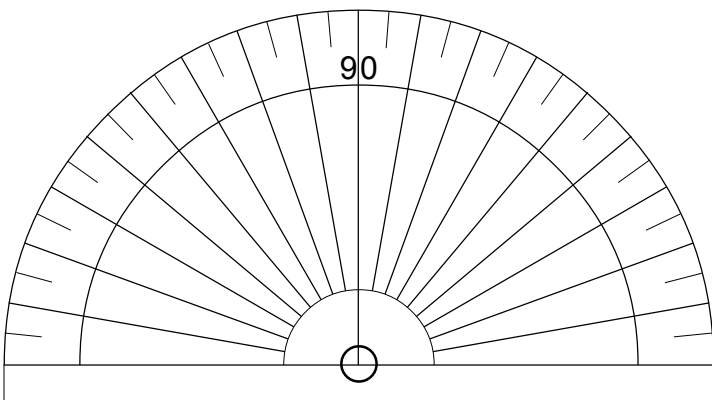
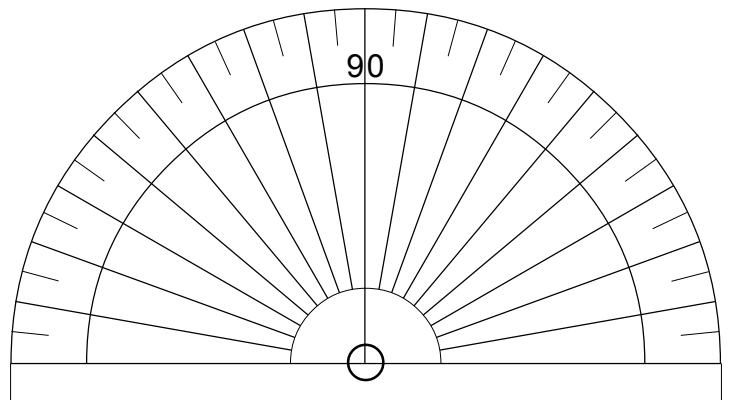
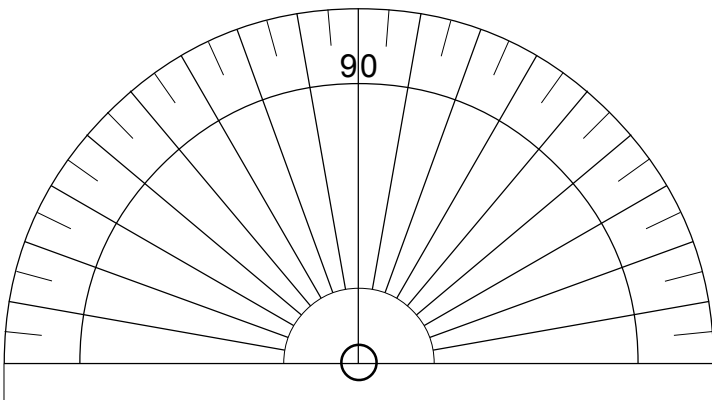
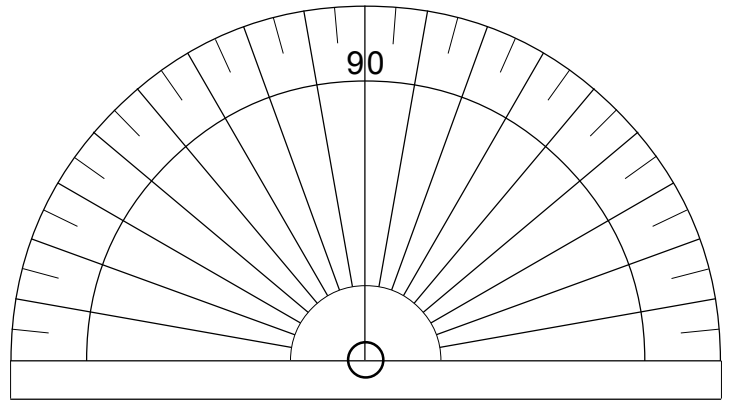
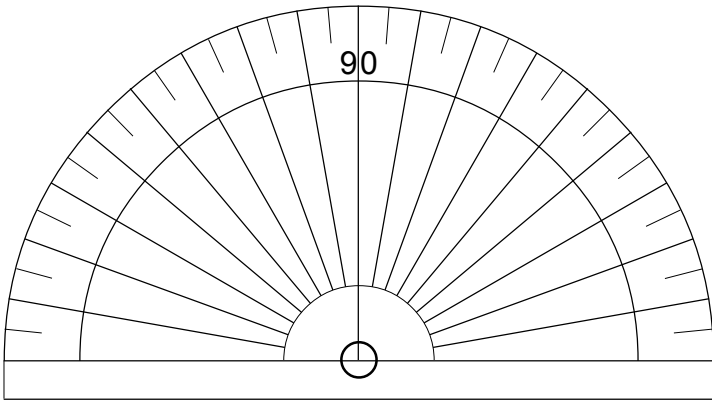
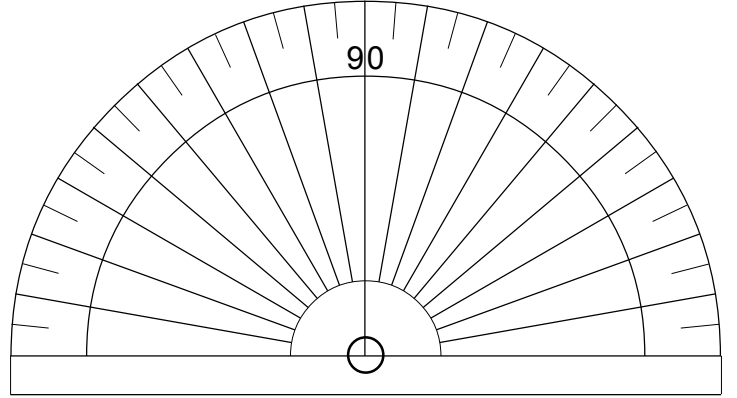
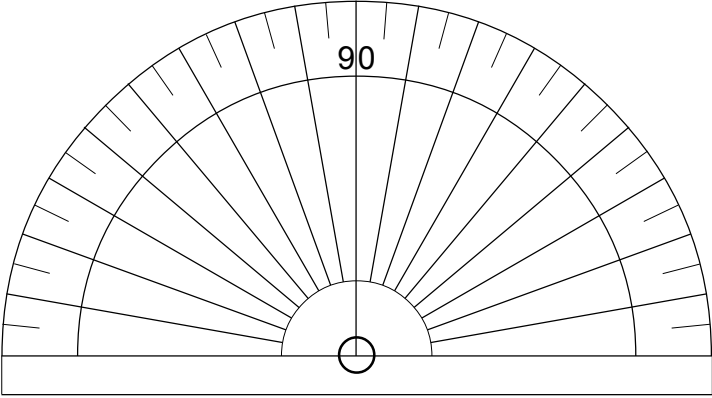
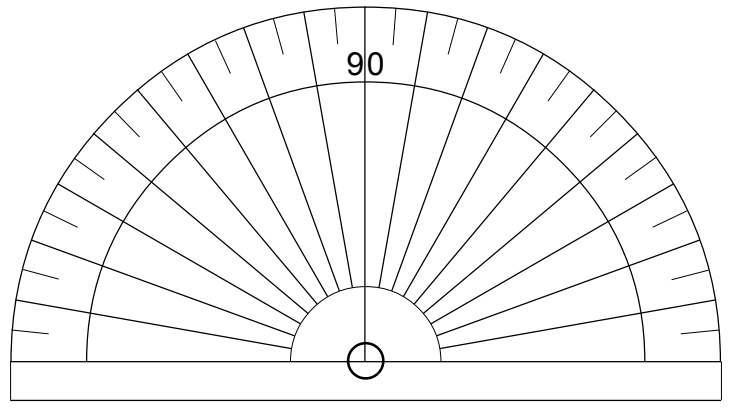
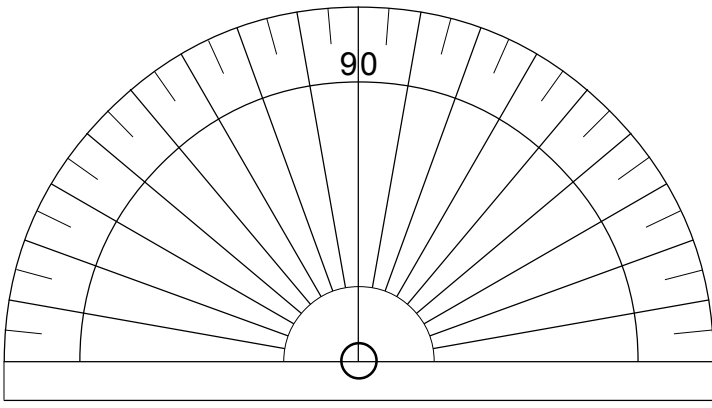

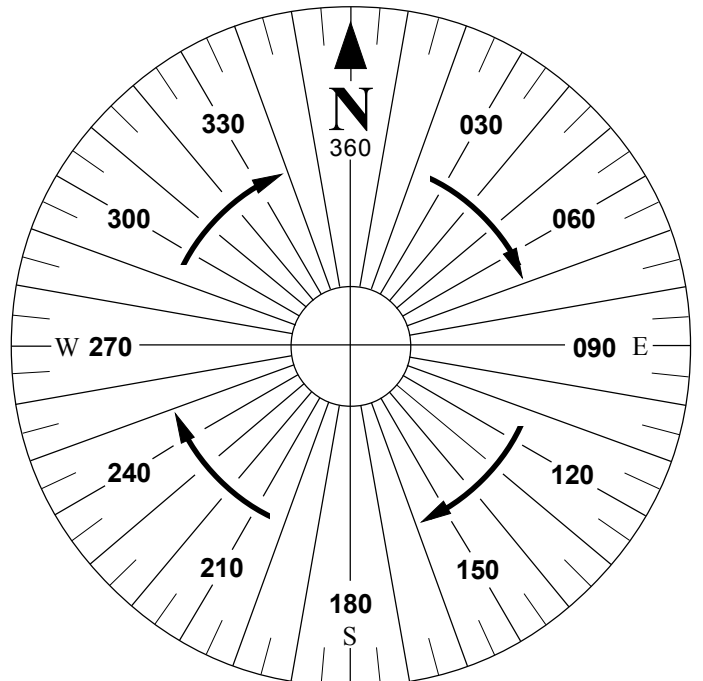
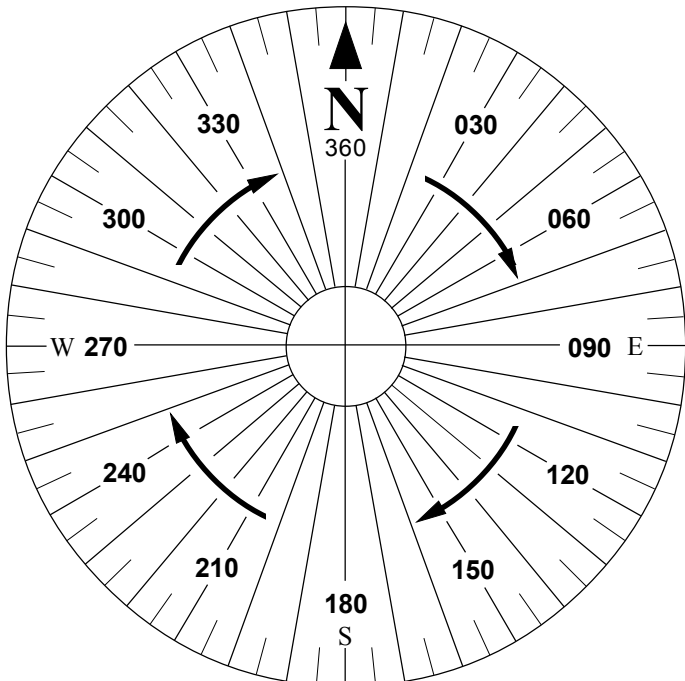
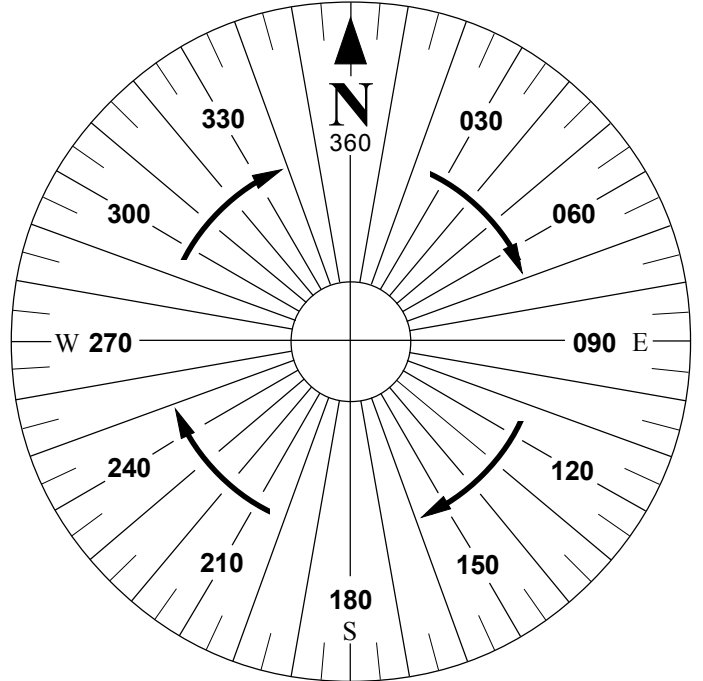
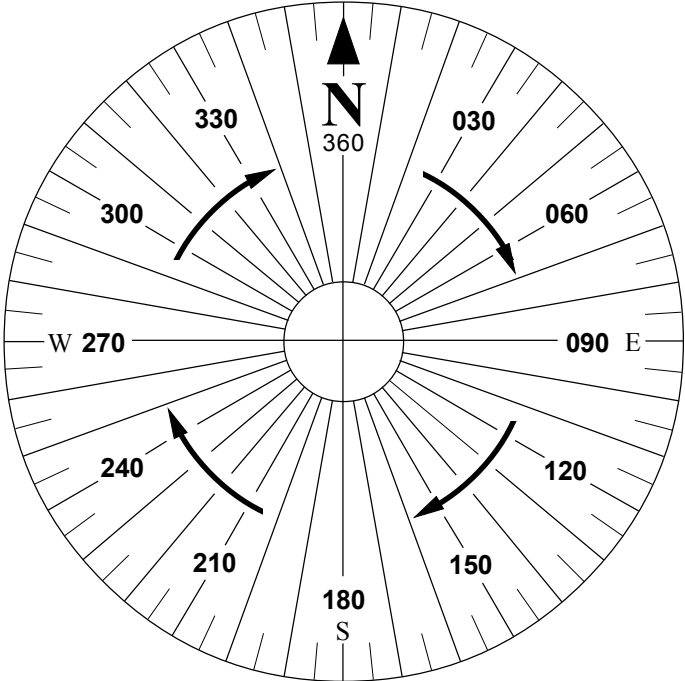
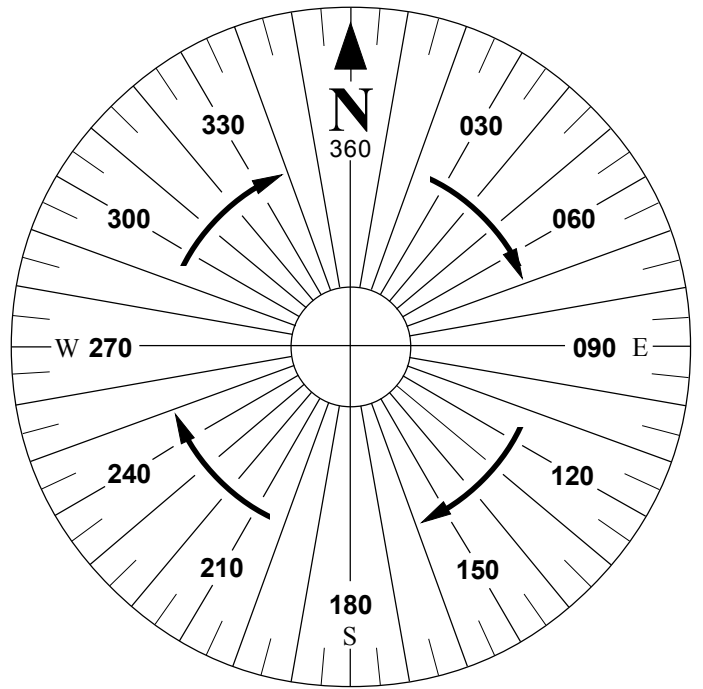
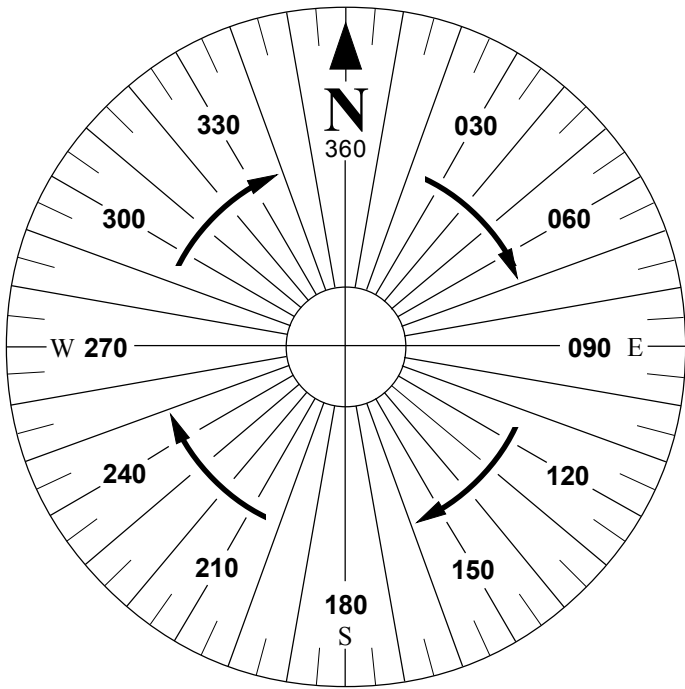

To make, first cut it out around the outside line.
 Score and fold up on the two broken lines for the 'back-sight' and 'fore-sight'.
 Cut out the shaded rectangle to make the fore-sight.
 Make a *small* hole for the back-sight. Then enlarge this hole just enough
 so that it can be looked through and the front sight seen clearly.
 Do NOT make it too big.

Make a *small* hole for the pivot point.
 Put a piece of thread through and then tie it not
 in it at the back.
 Fasten a light weight to the other
 the th.

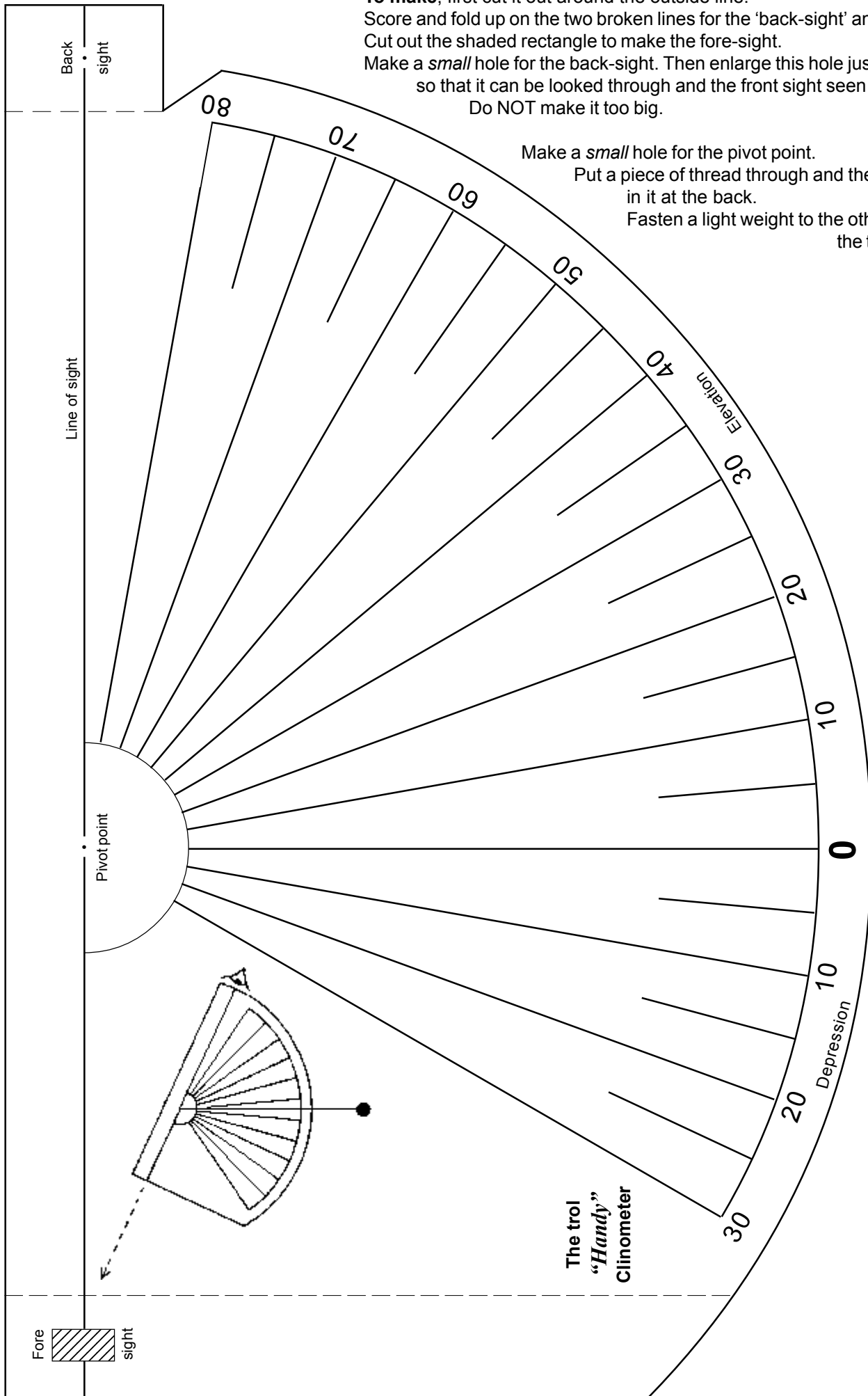

Tower of Hanoi ~ Puzzle Pieces

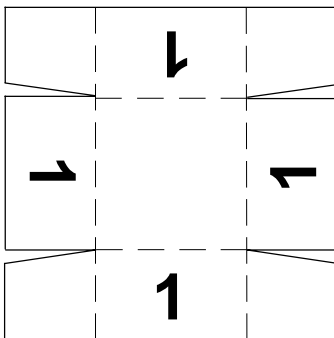
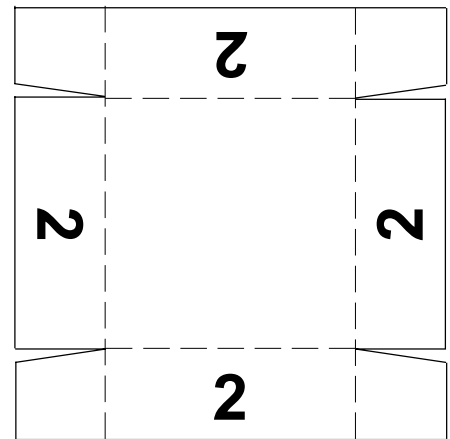
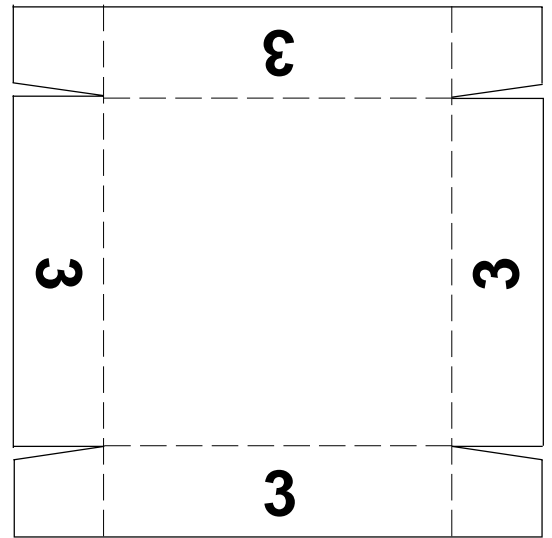
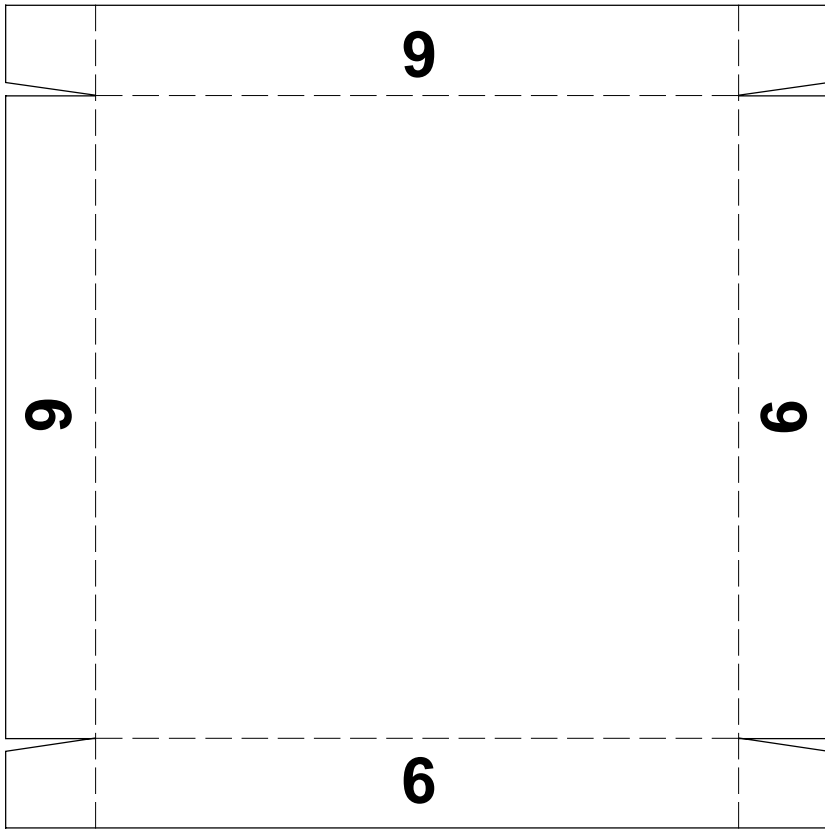

To make each one, cut out along all solid lines. Score along broken lines and fold down to make sides. Turn in and glue small flaps to adjacent sides to make a shallow 'box' or 'tray'.

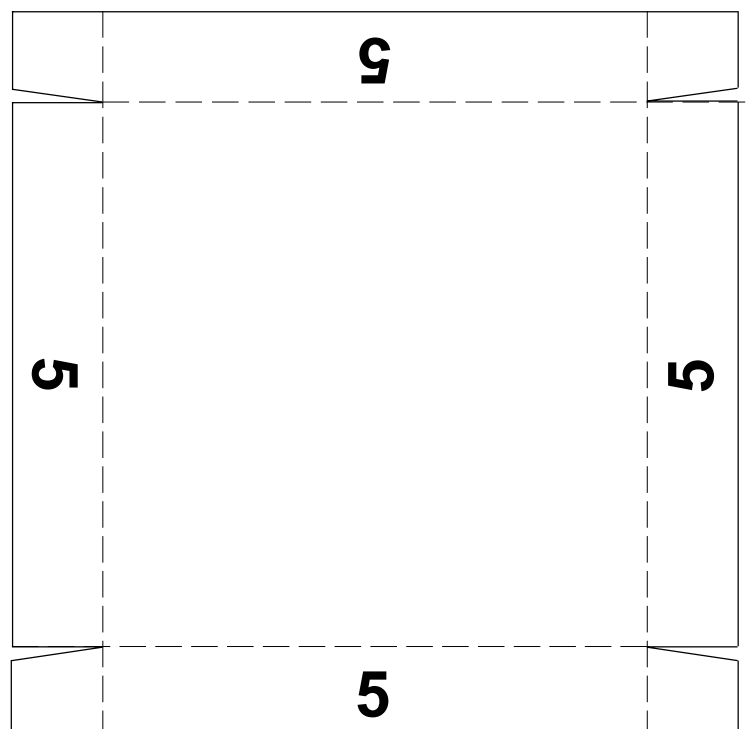
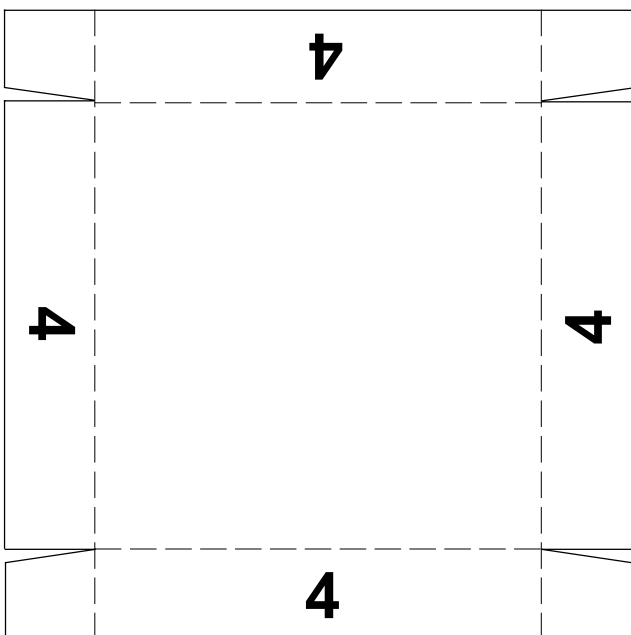

Tower of Hanoi ~ Baseboard for Puzzle

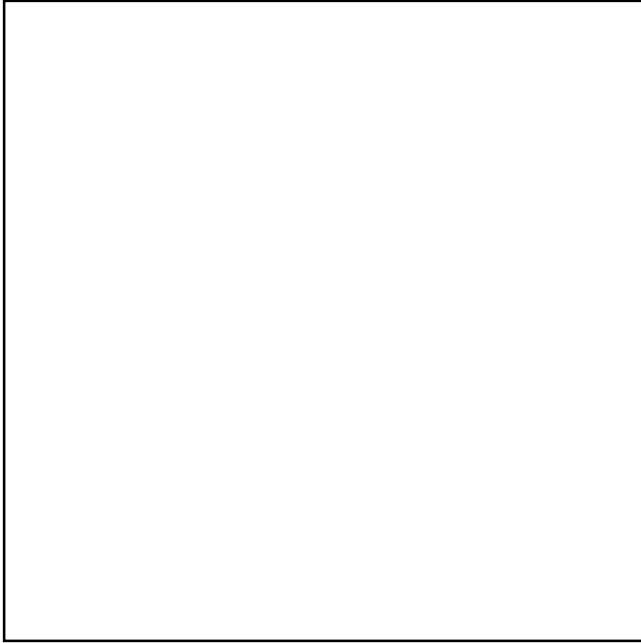

A

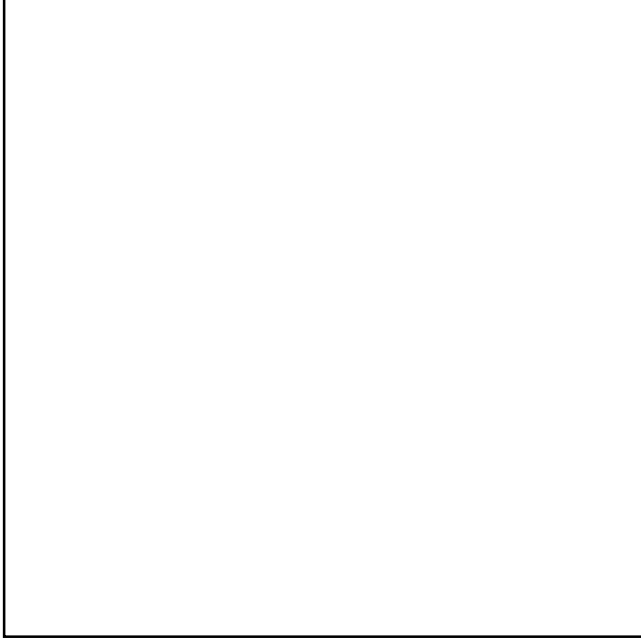

B

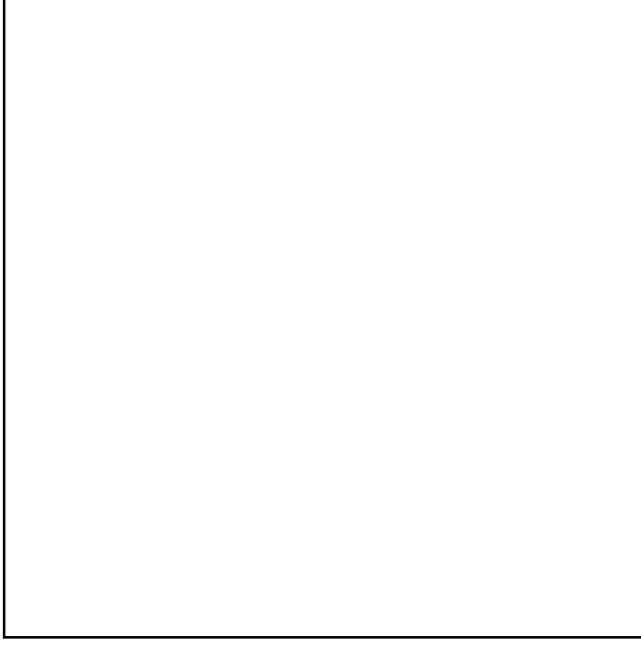

C

Start with all the pieces in one pile, smallest at the top, largest at the bottom, on position A

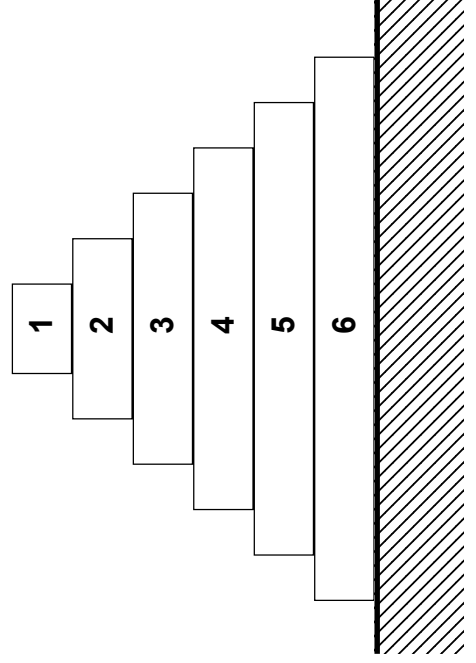

The **puzzle** is to move this first pile to position **B** (or C) keeping to these rules:

Only **ONE** piece may be moved at a time.

Pieces may only be moved to one of the three positions marked **A**, **B** or **C**.

Any number of pieces may be piled onto any position, **BUT** a bigger piece is **NEVER** to be placed on top of a smaller piece.

The "Ten-talizer" Puzzle

First make the 4 cubes whose nets are given here.
 Cut each one out following the outside 'solid' line.
 Score and fold on the 'broken' lines.
 Glue the tabs in their numbered order.

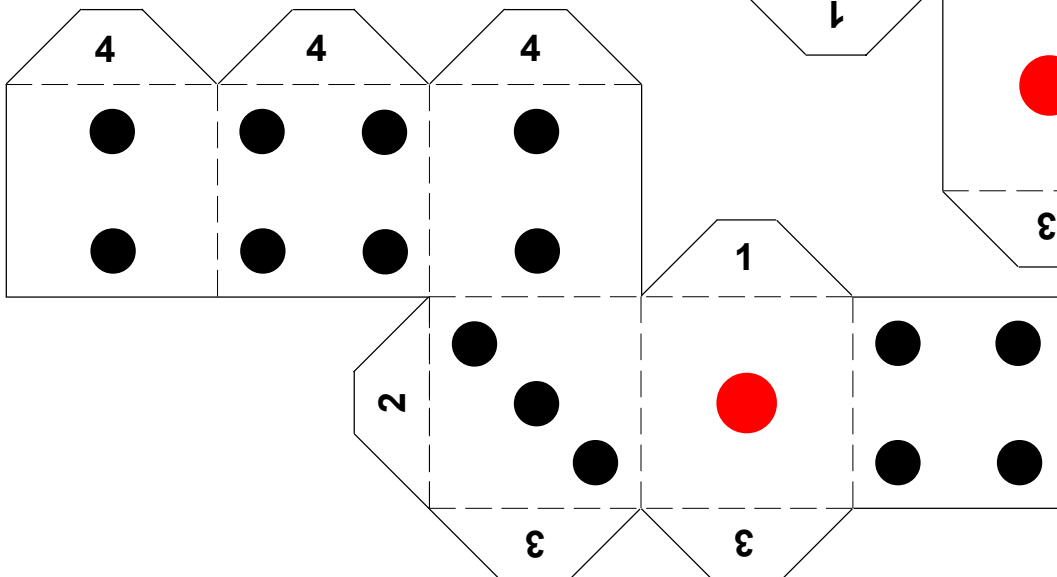
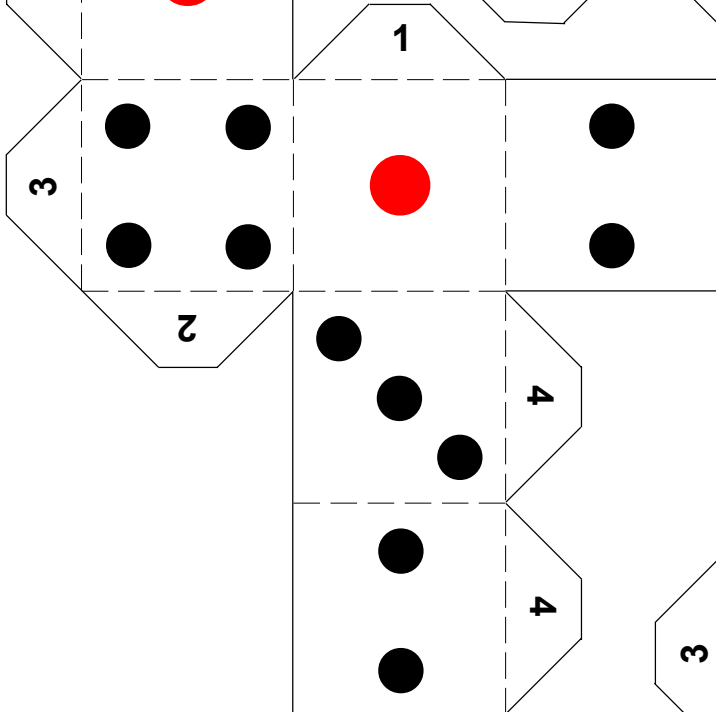
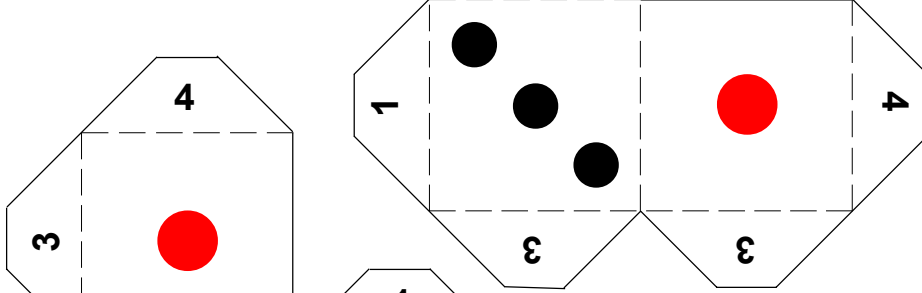
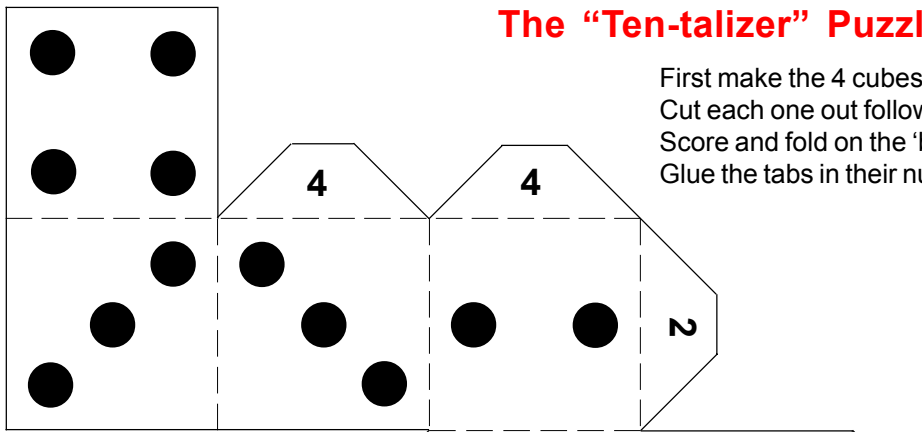
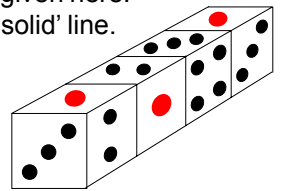

The Puzzles

There are 5 separate puzzles.

In each of them the 4 cubes have to be set down in a straight line and all the dots showing on the 4 faces along one side have to be added up. The object is to make these 4 faces add up to 10.

- FIRST - Along any ONE side.
- SECOND - Along any TWO sides.
- THIRD - Along any THREE sides.
- FOURTH - Along ALL four sides.
- FIFTH, so that the 4 faces show 1, 2, 3, 4 (in any order) along ALL four sides.

(The last has only one possible solution)

MacMahon Tiles

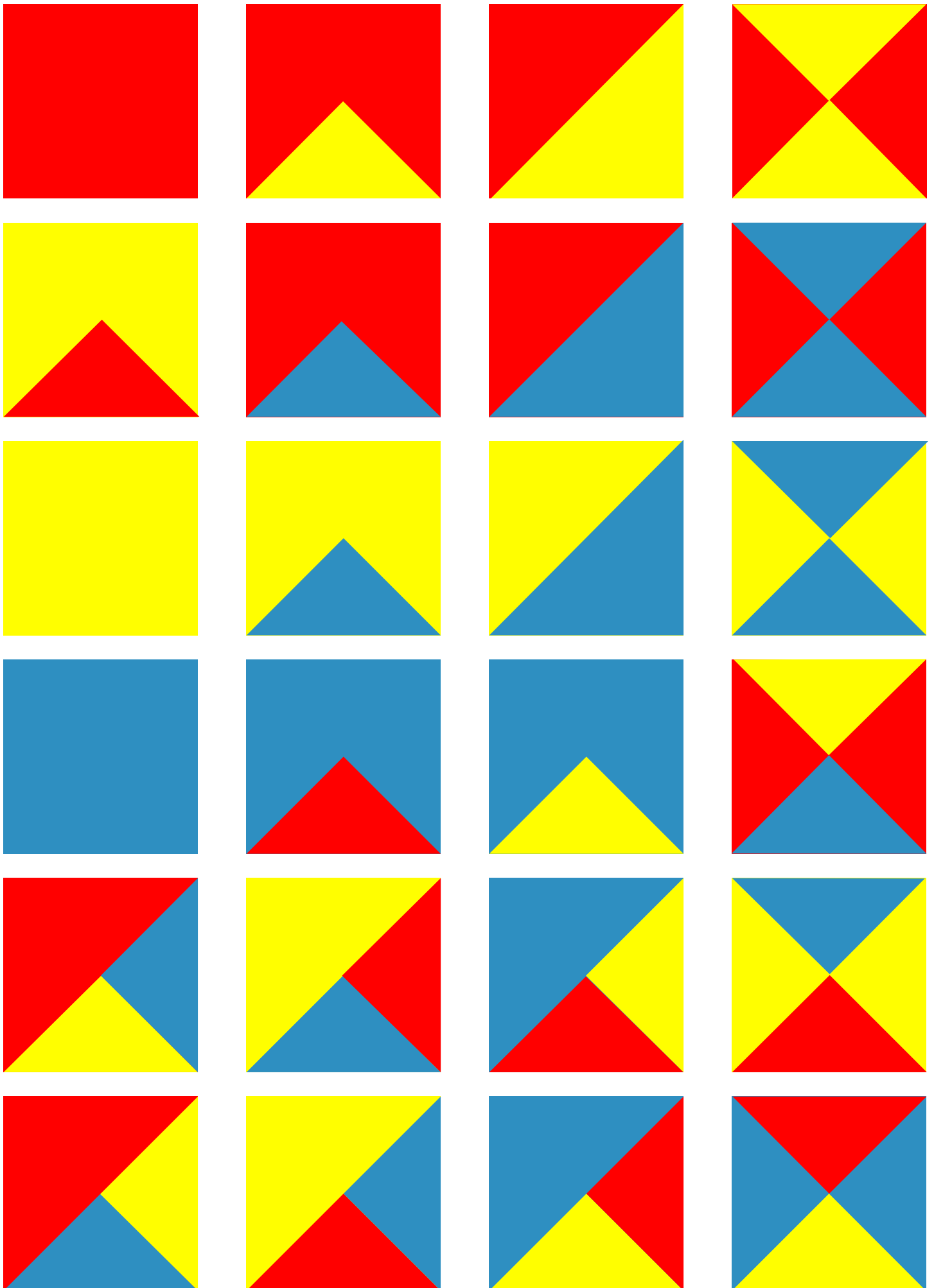

Solution to a MacMahon Tile Puzzle

This just one way (out of 12,000+) of making a 6 by 4 rectangle with the 24 MacMahon tiles, where they all match in colour along touching edges and the border is made of only one colour.

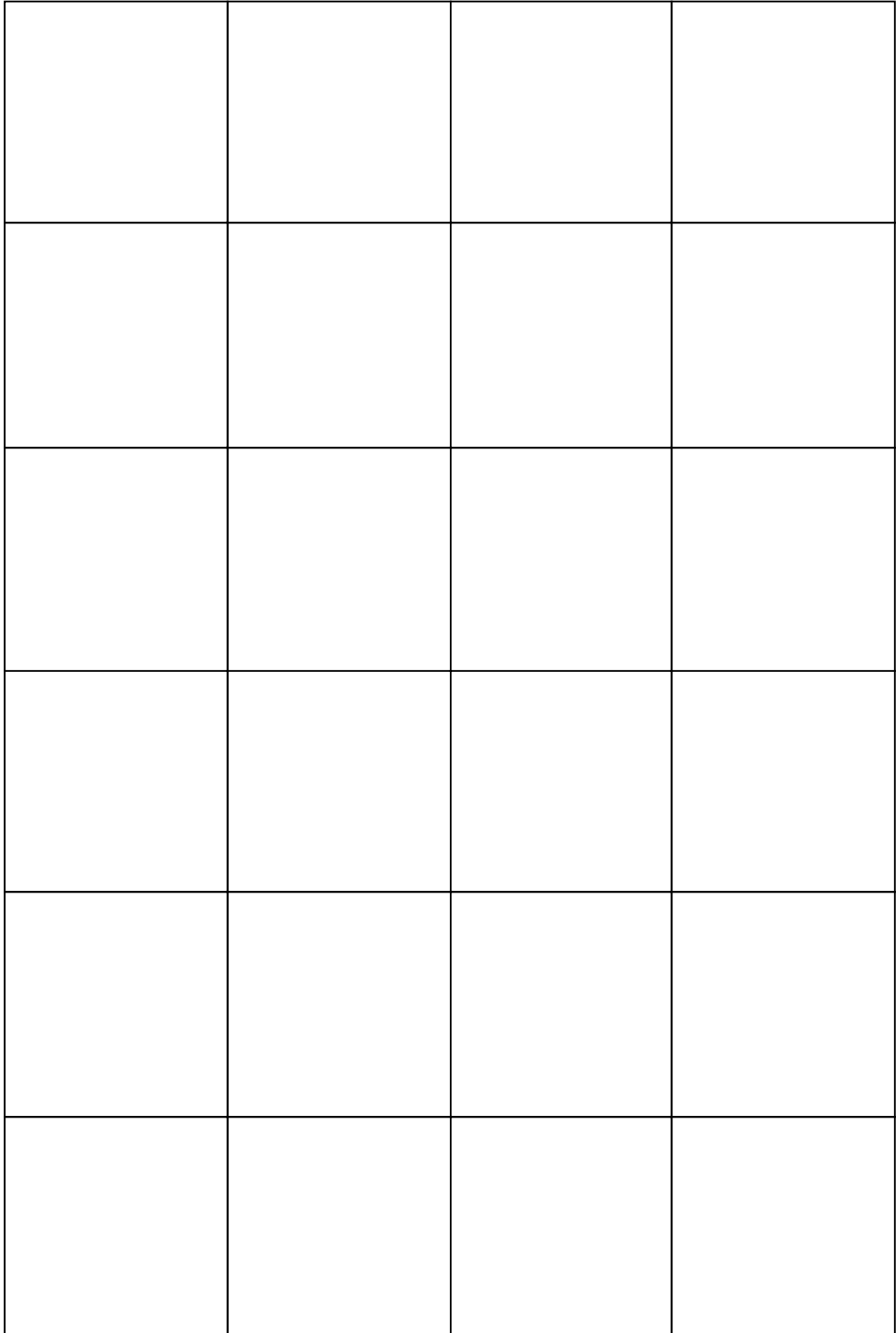

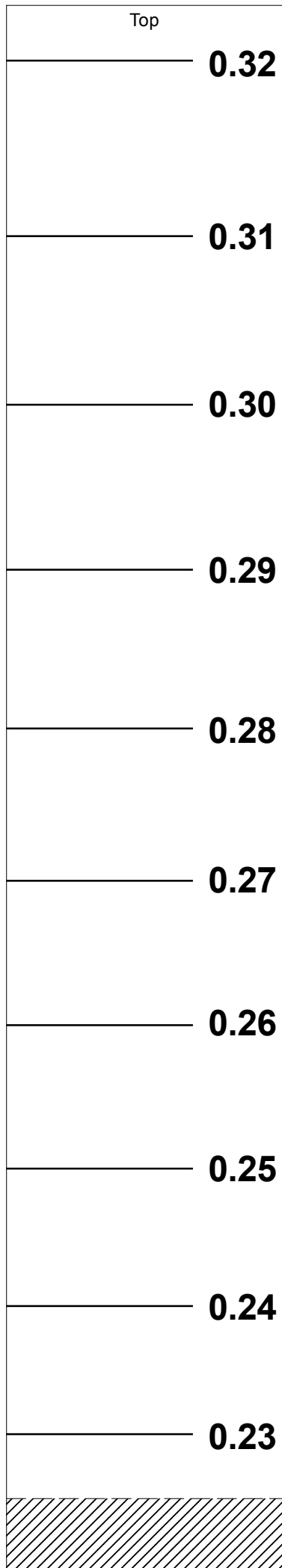

The Reaction Timer Drop Tester

To make,
cut out both of the oblong strips.
Then glue the top edge of the strip
with the smaller numbers on it to
the bottom edge of the other strip.
The lower strip must exactly
overlap only the shaded area up to
the dashed line.
This needs to be done with care to
ensure the accuracy of the timing.

Napier's Rods

×	0	1	2	3	4	5	6	7	8	9
1	0 0	0 1	0 2	0 3	0 4	0 5	0 6	0 7	0 8	0 9
2	0 0	0 2	0 4	0 6	0 8	1 0	1 2	1 4	1 6	1 8
3	0 0	0 3	0 6	0 9	1 2	1 5	1 8	2 1	2 4	2 7
4	0 0	0 4	0 8	1 2	1 6	2 0	2 4	2 8	3 2	3 6
5	0 0	0 5	1 0	1 5	2 0	2 5	3 0	3 5	4 0	4 5
6	0 0	0 6	1 2	1 8	2 4	3 0	3 6	4 2	4 8	5 4
7	0 0	0 7	1 4	2 1	2 8	3 5	4 2	4 9	5 6	6 3
8	0 0	0 8	1 6	2 4	3 2	4 0	4 8	5 6	6 4	7 2
9	0 0	0 9	1 8	2 7	3 6	4 5	5 4	6 3	7 2	8 1

↑ ↑ ↑ ↑ ↑ ↑ ↑ ↑ ↑ ↑ ↑ ↑

To make, cut along the 12 lines indicated by arrows, and then trim off the top and bottom of each strip.
Instructions on the use of these rods are given on a separate sheet.

Napier's Rods

Instructions for their use

These rods are used for multiplication of a number (of any length) by a single digit number.

Consider the sum 47526×7

Whatever the sum, the first rod that is always needed is the one headed \times (the multiplication sign) which is referred to as the **index rod**.

Place the index rod down and then to the left of it, place the rods headed 4 7 5 2 6 in that order.

Go down the index rod to the level of the multiplier (7 in this case) and look at that row.

This situation, stripped of all other lines and numbers is shown below.

\times	4	7	5	2	6
7	2	4	3	1	4
	8	9	5	4	2

Notice it is made up of a triangle at each end holding one number, with a set of parallelograms between them each holding two numbers.

The answer to the sum can now be read off from that row, working from right to left.

- Starting at the triangle on the right-hand end we have a 2 *write* 2 (=2)
- Move left to a parallelogram, add the two numbers (4 + 4) to get 8 *write* 8 (=82)
- Move left to a parallelogram, add the two numbers (5 + 1) to get 6 *write* 6 (=682)
- Move left to a parallelogram, add the two numbers (9 + 3) to get 12
which must be split into 1 and 2, the 1 is 'carried' leaving 2 *write* 2 (=2682)
- Move left to a parallelogram, add the two numbers (8 + 4)
plus the 1 that was carried to get 13
which must be split into 1 and 3, the 1 is 'carried' leaving 3 *write* 3 (=32682)
- Move left to the last triangle where there is a 2
plus the 1 that was carried makes 3 *write* 3 (=332682)

And the final answer is

332682

Put another way, by 'straightening out' the pairs of numbers in each of the parallelograms, we can see better all that was done was the addition sum shown on the right.

$$\begin{array}{r}
 2\ 4\ 3\ 1\ 4 \\
 +\ 8\ 9\ 5\ 4\ 2 \\
 \hline
 3\ 3\ 2\ 6\ 8\ 2
 \end{array}$$

Note that if the number to be multiplied contains repeated digits, it cannot be done with a single set, more rods will have to be found.

Historical Note

These 'rods' were invented by John Napier (1550-1617), 8th Baron of Merchiston. He was a Scottish mathematician who also did a lot of writing on religious matters.

He is credited as being the inventor of logarithms, which he described in a book in 1614. Though they were not quite in the form that we know now, the principle was the same.

His rods were produced commercially, made up in bone or wood of square section, with each of the long faces having one rod engraved upon it. In this way it was possible to have several numbers repeated. These rods are often referred to as Napier's bones.

He devised other methods which simplified multiplication by reducing it to addition, some being more useful than others.

Genaille's Rods

x		0	1	2	3	4	5	6	7	8	9
1	0	0	1	2	3	4	5	6	7	8	9
2	0	0	2	4	6	8	0	2	4	6	8
	1	1	3	5	7	9	1	3	5	7	9
3	0	0	3	6	9	2	5	8	1	4	7
	1	1	4	7	0	3	6	9	2	5	8
	2	2	5	8	1	4	7	0	3	6	9
4	0	0	4	8	2	6	0	4	8	2	6
	1	1	5	9	3	7	1	5	9	3	7
	2	2	6	0	4	8	2	6	0	4	8
	3	3	7	1	5	9	3	7	1	5	9
5	0	0	5	0	5	0	5	0	5	0	5
	1	1	6	1	6	1	6	1	6	1	6
	2	2	7	2	7	2	7	2	7	2	7
	3	3	8	3	8	3	8	3	8	3	8
	4	4	9	4	9	4	9	4	9	4	9
6	0	0	6	2	8	4	0	6	2	8	4
	1	1	7	3	9	5	1	7	3	9	5
	2	2	8	4	0	6	2	8	4	0	6
	3	3	9	5	1	7	3	9	5	1	7
	4	4	0	6	2	8	4	0	6	2	8
	5	5	1	7	3	9	5	1	7	3	9
7	0	0	7	4	1	8	5	2	9	6	3
	1	1	8	5	2	9	6	3	0	7	4
	2	2	9	6	3	0	7	4	1	8	5
	3	3	0	7	4	1	8	5	2	9	6
	4	4	1	8	5	2	9	6	3	0	7
	5	5	2	9	6	3	0	7	4	1	8
	6	6	3	0	7	4	1	8	5	2	9
8	0	0	8	6	4	2	0	8	6	4	2
	1	1	9	7	5	3	1	9	7	5	3
	2	2	0	8	6	4	2	0	8	6	4
	3	3	1	9	7	5	3	1	9	7	5
	4	4	2	0	8	6	4	2	0	8	6
	5	5	3	1	9	7	5	3	1	9	7
	6	6	4	2	0	8	6	4	2	0	8
	7	7	5	3	1	9	7	5	3	1	9
9	0	0	9	8	7	6	5	4	3	2	1
	1	1	0	9	8	7	6	5	4	3	2
	2	2	1	0	9	8	7	6	5	4	3
	3	3	2	1	0	9	8	7	6	5	4
	4	4	3	2	1	0	9	8	7	6	5
	5	5	4	3	2	1	0	9	8	7	6
	6	6	5	4	3	2	1	0	9	8	7
	7	7	6	5	4	3	2	1	0	9	8
	8	8	7	6	5	4	3	2	1	0	9

↑ ↑ ↑ ↑ ↑ ↑ ↑ ↑ ↑ ↑ ↑ ↑

To make, cut along the 12 lines indicated by arrows, and then trim off the top and bottom of each strip.
Instructions on the use of these rods are given on a separate sheet.

Slide Rule

To make

Cut out the two strips on the right.

Notice that the wider strip, which has a D in its top left-hand corner, has its ends drawn.

The narrower strip, which has a C in its top left-hand corner, has no apparent ends. It should be cut the full length of the paper or card on which it is printed. The reason for this will become clear when it is put into use. If, at that time, it seems to be inconveniently long it can be trimmed to suit.

The D strip has to be folded on the dashed line. This is best done by using a ruler or straight edge. Score the line and then, holding the ruler firmly on the line bend the flap upwards. The flap needs to be folded so as to lie on the same side of the strip, forming a valley, as that on which the numbers are printed.

The C strip is dropped into this valley so that the two scales line up, and the slide rule is then ready for use.

Instructions on the use of this slide rule are given on a separate sheet.

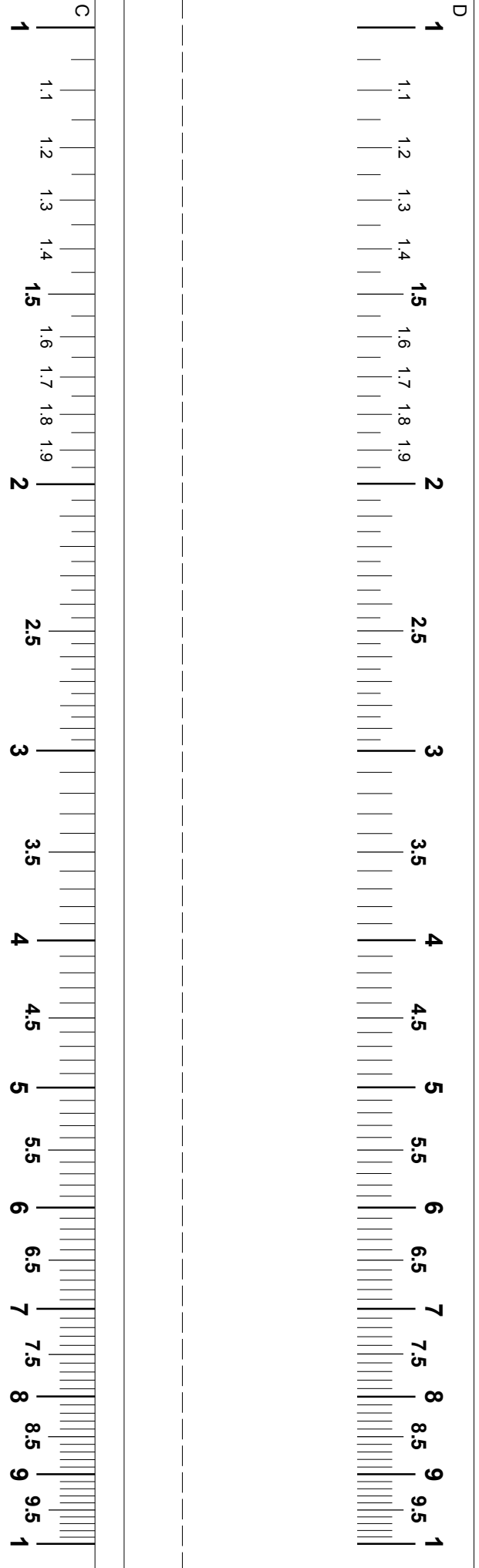

Slide Rule

Instructions for Use

It is assumed that the Slide Rule has been cut out and is ready for use. Note that the two identical scales are identified as **C** and **D**. **D** can be thought of as the fixed scale, and **C** as the moving scale.

Simple though this model is, it is capable of doing multiplication and division, giving answers to an accuracy of 2 significant figures in all cases and, with care, to 3 significant figures in many other cases.

As a first example, consider the sum 2×3 (always start with something to which the answer is known). There are only two steps:

1. Find **2** on the **D** scale and move the **C** scale to put the **1** (which is at the left-hand end) in line with that **2**
2. Find **3** on the **C** scale and read off the number which is in line with it on the **D** scale.
That is the answer. (It should be 6)

Now, *without moving anything*, we are able to read off the answers to some other sums which are of the form $2 \times ?$

For 2×4 we find the **4** on the **C** scale and read-off **8** on the **D** scale.

For 2×3.5 we find **3.5** on the **C** scale and read-off **7** on the **D** scale.

For 2×4.7 we find **4.7** on the **C** scale and read-off **9.4** on the **D** scale.

For 2×1.85 we find **1.85** on the **C** scale and read-off **3.7** on the **D** scale.
and so on.

What happens when we want to do 2×6 ? It seems to be beyond the range of the **D** scale. The way out of this lies in the way these scales are made. The 1 at the left-hand end can be considered as being the same as the 1 at the right-hand end. It is as though the scale was bent around in a circle. (Indeed, some slide rules are made in a circular format.)

So, to do 2×6 we put the right-hand **1** of the **C** scale in line with the **2** of the **D** scale.

Now the **6** of the **C** scale should point to a value that is on **D** scale.

It does, but it does not seem to be the answer we expected!

It is **1.2** instead of **12**, so what has gone wrong?

Quite simply, **the slide rule does not know about decimal points**, and it is up to the user to know where the decimal point must go in the answer.

There are different ways of working this out, but the best way is to make an estimate of the size of the answer by making an approximation. In this case, our estimate would be that $2 \times 6 = 12$ but we never needed the slide rule for that anyway!

Now, suppose the sum had been 2.2×5.9 A first estimate for that would be $2 \times 6 = 12$

Then we put the right-hand **1** of the **C** scale in line with the **2.2** of the **D** scale, go along to **5.9** on the **C** scale, and see that it points to **1.3** on the **D** scale

Our estimate was 12, so it must be that $2.2 \times 5.9 = 13$ (*it is actually 12.98*)

Those same settings on the slide rule, allied to the right estimate, would also allow us to find that
 $220 \times 5,900 = 13,000$

Clearly, making good estimates is essential to getting accurate answers from a slide rule.

Division

On a slide rule, this is simpler than multiplication.

Using the example $6 \div 3$

Find **6** on the **D** scale and **3** on the **C** scale.

Put the **3** under the **6**

The answer will be shown (on the **D** scale) above the **1** on the **C** scale.

Once again, estimation plays an important part in work with more 'serious' numbers.