

SCHOOL:

Year 12 Mathematics Challenge 2010
Round 3 Problem Solving (40 marks) -
Answers

Task A. Towers (Calculate all answers in terms of Π)

A tower is built by placing discs of thickness 1cm, one on top of another.
 The radius of the disc directly below is 2cm more than the disc above.

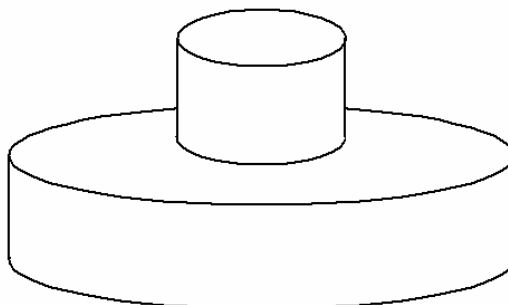

The diagram above shows a disc of radius 1cm resting on a disc of 3 cm.

(i) Calculate the surface area of the tower
 (include the hidden base!)

26Π 2 marks

An additional disc is added to the tower:

(ii) What is the radius of the additional disc?

5 cm 1 mark

Calculate the surface area of the tower.

68Π 3 marks

A tower is constructed from 10 discs, the top disc being of radius 1cm:

(iii) Calculate the surface area of this tower.

922Π 3 marks

A tower has 'n' discs with the top disc being of radius 1cm:

(iv) Find a formula for the surface area of the tower.

$2\Pi(5n^2-4n+1)$ or equiv
 3 marks -1 each coeff error

A tower of 10 discs, the top disc being of radius 1cm, has the top 5 discs removed:

(v) Calculate the surface area of the remaining tower.

872Π 3 marks

SCHOOL:

Task B.

A symmetric trapezium is drawn on an isometric grid so that three lengths are equal.

So a trapezium of length 1 looks like this.

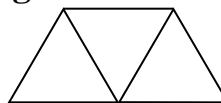

There are 6 trapeziums of length 1 in this hexagon.

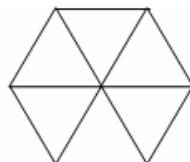

Make sure you can see them all.

A trapezium of length 2 looks like this.

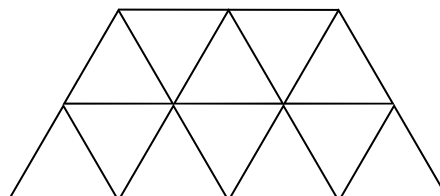

How many trapeziums of length 1 can be found in a trapezium of length 2? Try to be logical and systematic to ensure that you find them all.

18 3 marks

Here is a trapezium of length 3. How many trapeziums of length 1 can be found in this trapezium?

53 3 marks

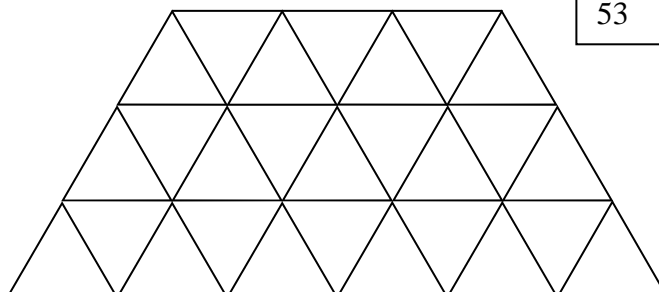

Complete the table below:

Size of the trapezium	Number of trapeziums of length 1
1	1
2	18
3	53
4	106 3 marks
5	177 3 marks

Find a rule for the number of trapezium of length 1 that can be found in a trapezium of length 'k'.

$9k^2 - 10k + 2$ (3 marks: -1 for each coefficient error)

SCHOOL:

Task C.

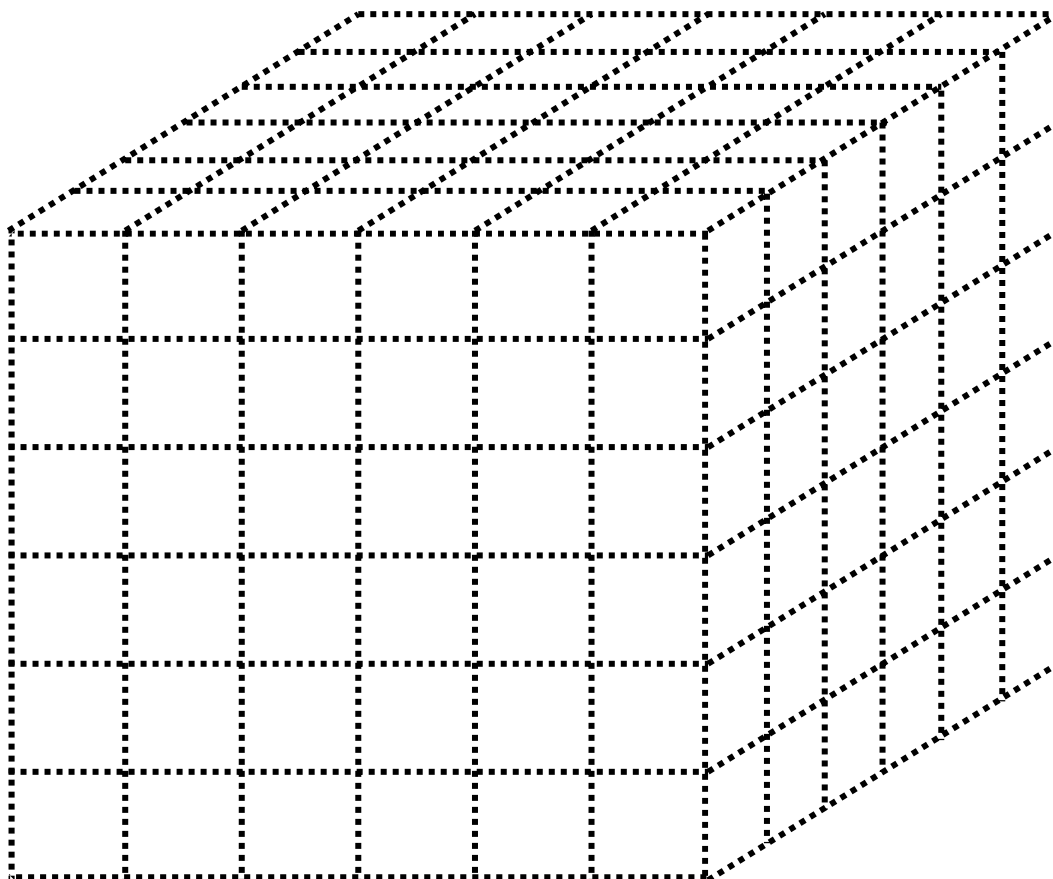

A 6 by 6 by 6 cube is made from 216 white cubes. The large cube is dipped in red paint and allowed to dry. How many cubes have:

<input style="width: 100px; height: 20px;" type="text"/>	1 red face	96	1 mark
	2 red faces	48	1 mark
	3 red faces	8	1 mark
	4 red faces	0	1 mark
	No red faces	64	1 mark

All the cubes with one red face are removed and the remaining structure is dipped in red paint again. How many cubes now have:

1 red face	24	1 mark
2 red faces	24	1 mark
3 red faces	16	1 mark
4 red faces	48	1 mark
No red faces	8	1 mark